

Föreläsning 9

IE1332 Utveckling av elektronikprodukter

Kapitel 14

- Skärmning

Behövs skärmning?

To shield or not to shield

- if predicted differential mode fields will exceed limits, shielding is essential
- if layout requires dispersed interfaces, shielding will probably be essential
- if layout allows concentrated interfaces, a ground plate may be adequate
- consider shielding only critical circuitry

Elektriskt fält dämpas av skärm

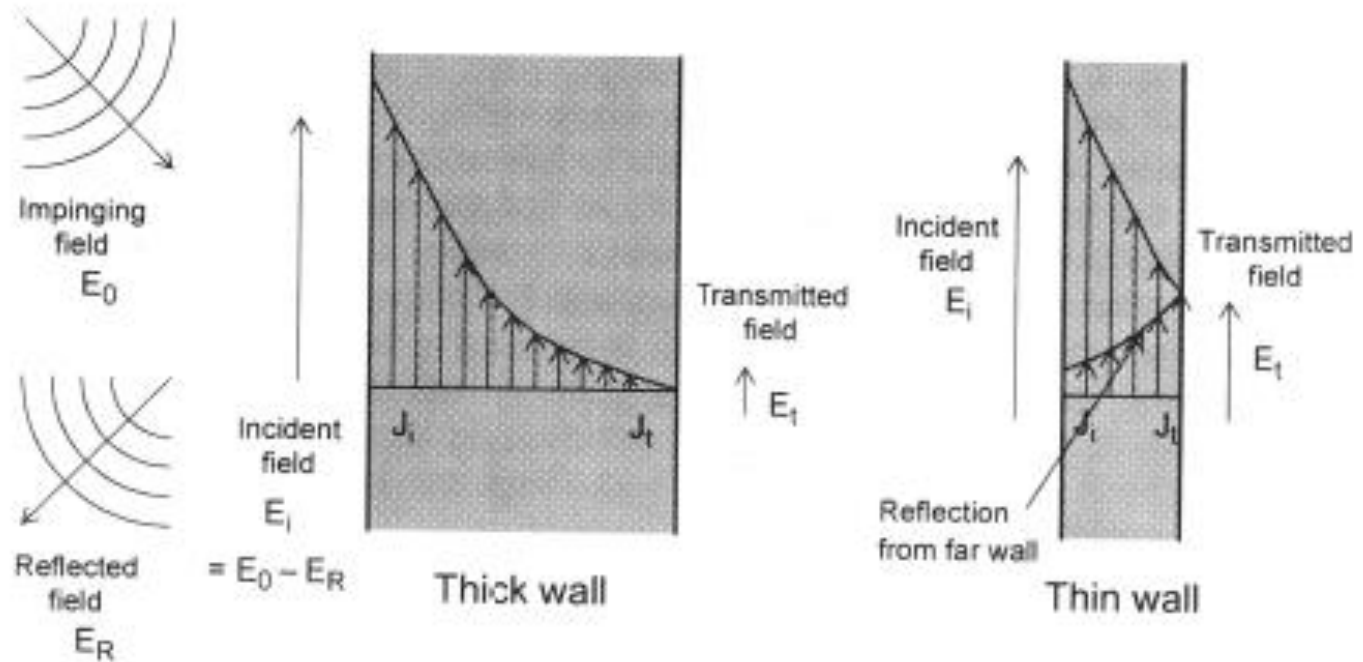

Figure 14.1 Reflection and absorption in an infinite barrier

Effektivitet vid olika frekvenser

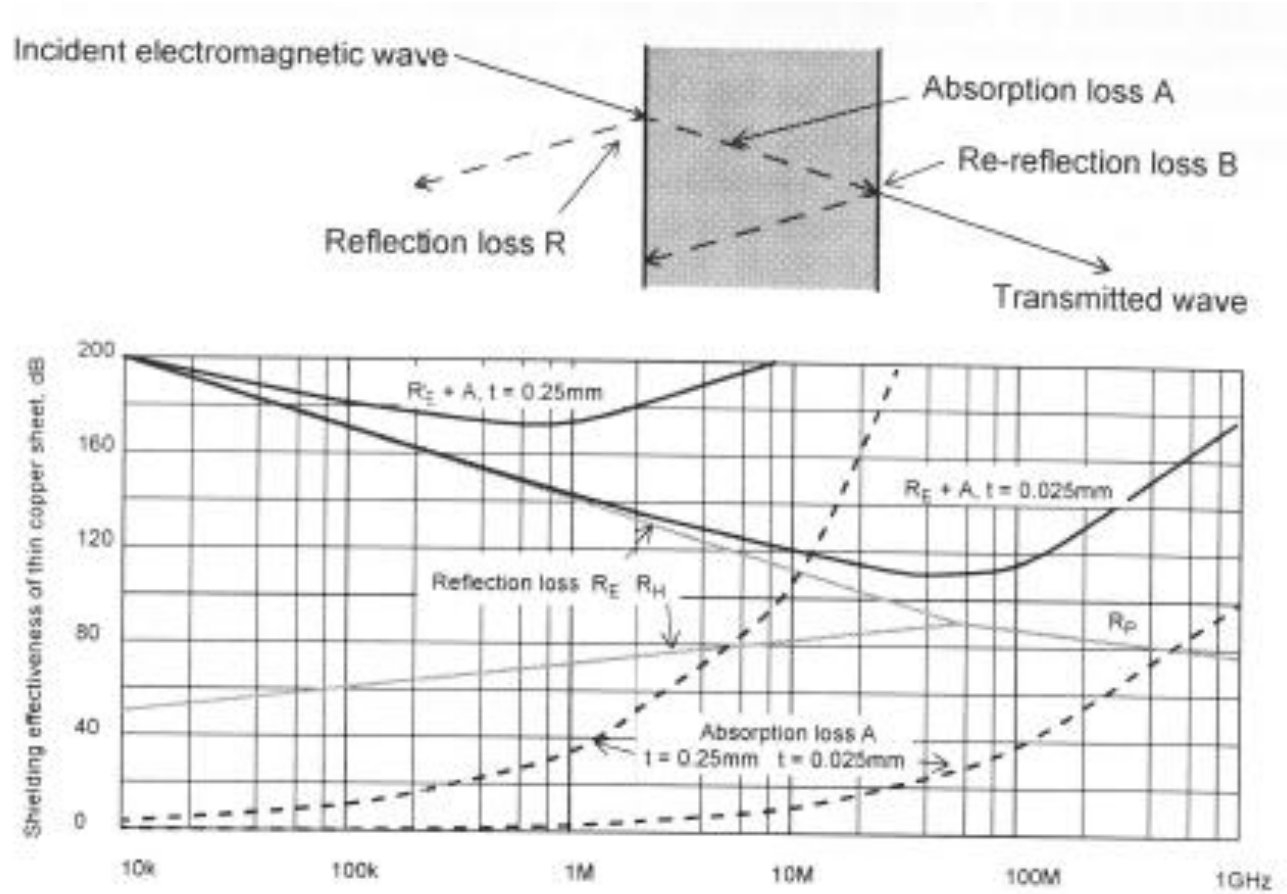
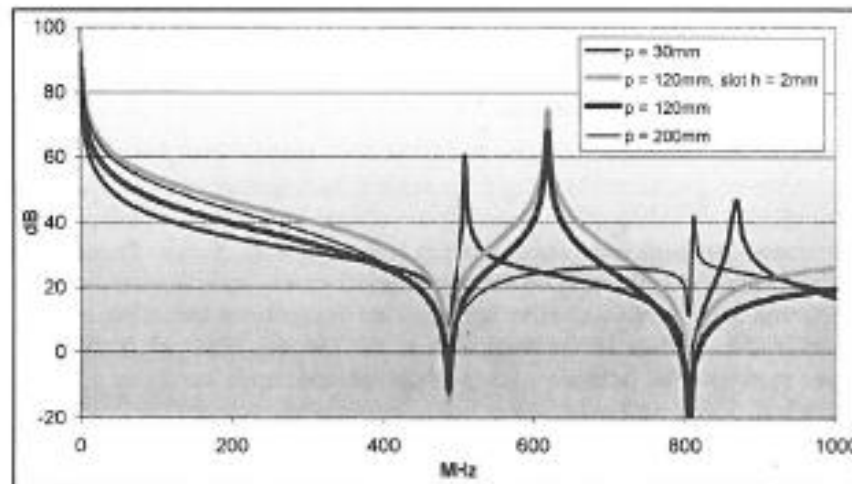
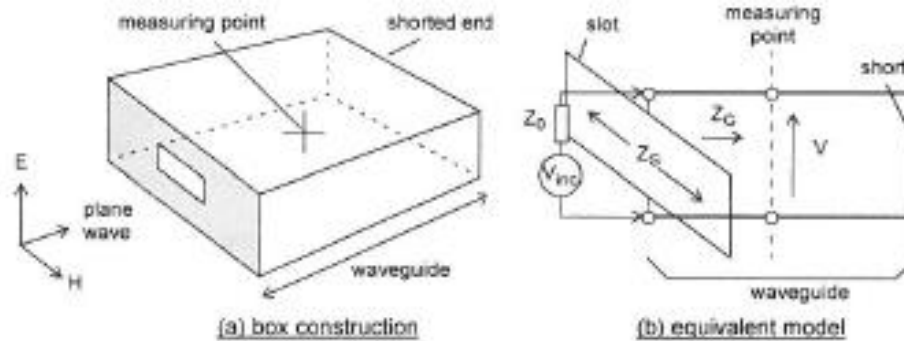

Figure 14.2 Shielding effectiveness versus frequency for a copper sheet of infinite extent

Fält i skärmad låda



(c) calculated example

Box dimensions: width 400mm, depth 400mm, height 133mm, slot width 100mm, slot height 20mm except where stated p is distance from face with slot

Figure 14.3 Modelling a rectangular box with a slot

Resonant låda

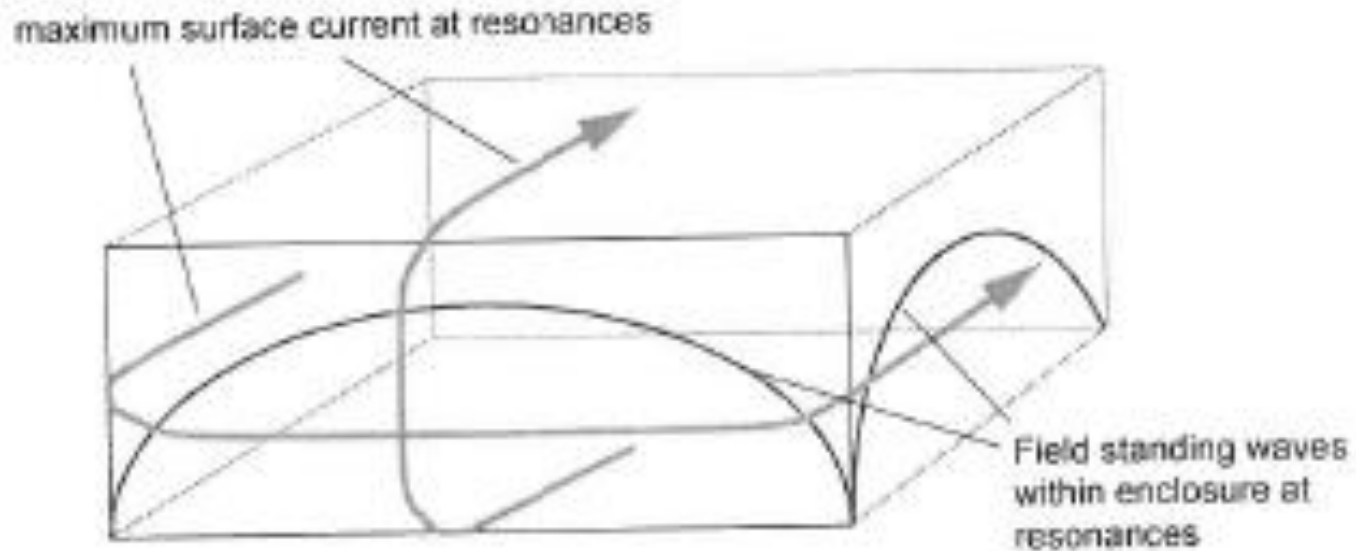

Figure 14.4 Resonances degrade shielding effectiveness

Skarvar i skärmen

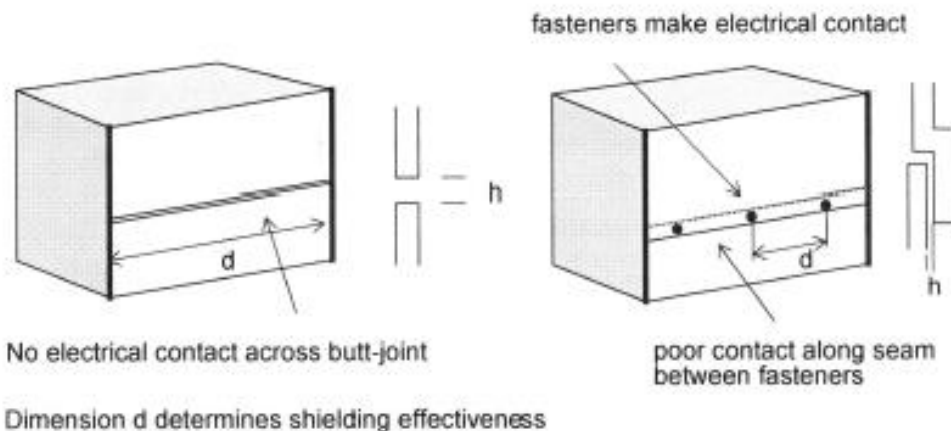

Figure 14.5 Seams between enclosure panels

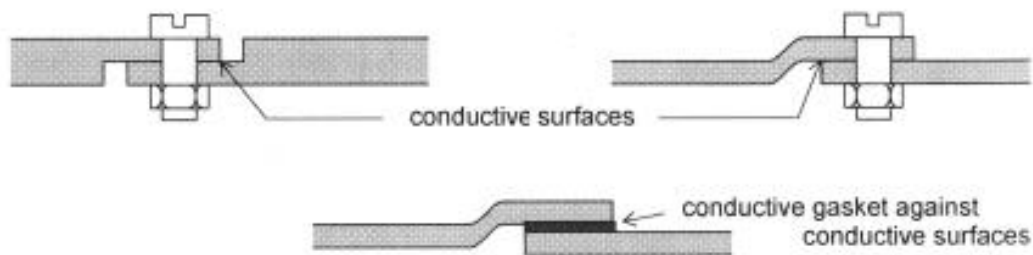

Figure 14.6 Cross-sections of joints for good conductivity

Öppningar som skär strömbanor

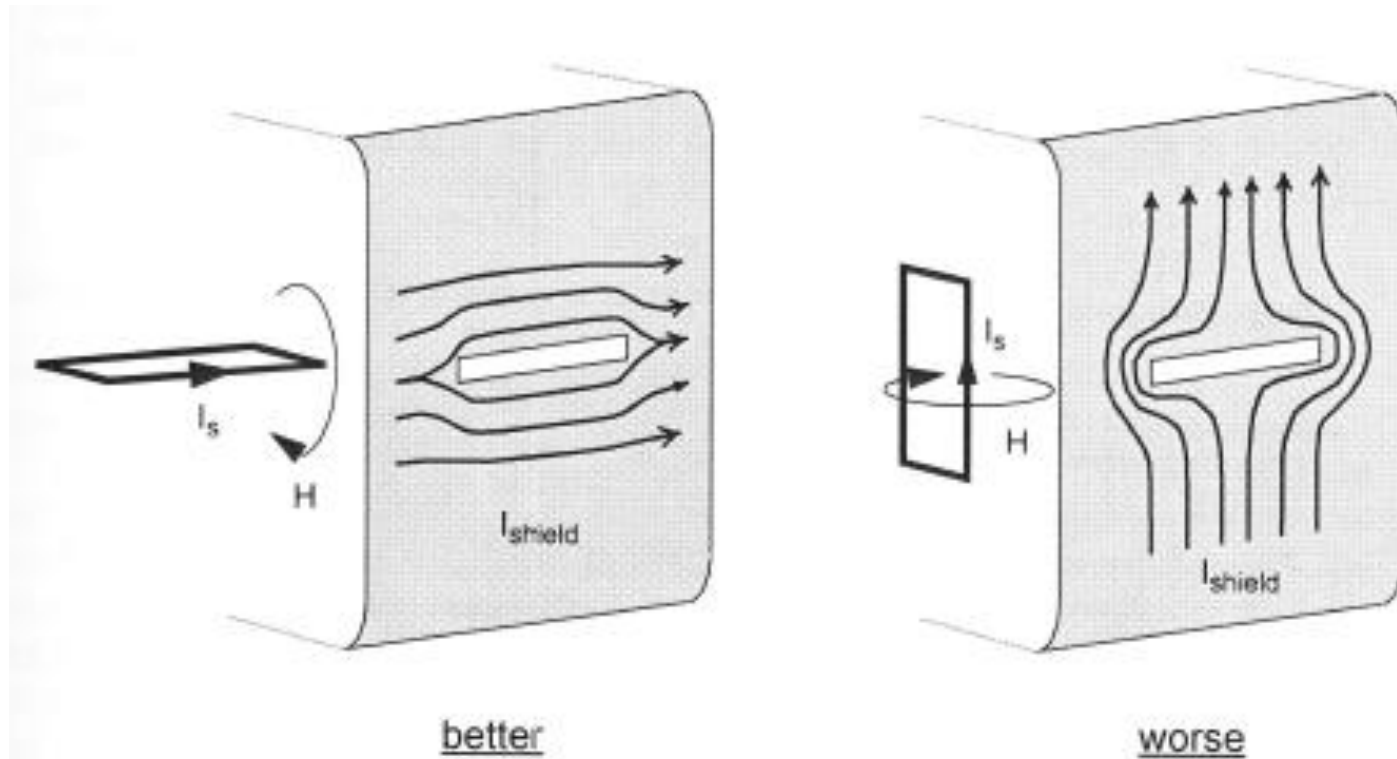

Figure 14.7 Current loop versus aperture orientation

Jordning av skärm

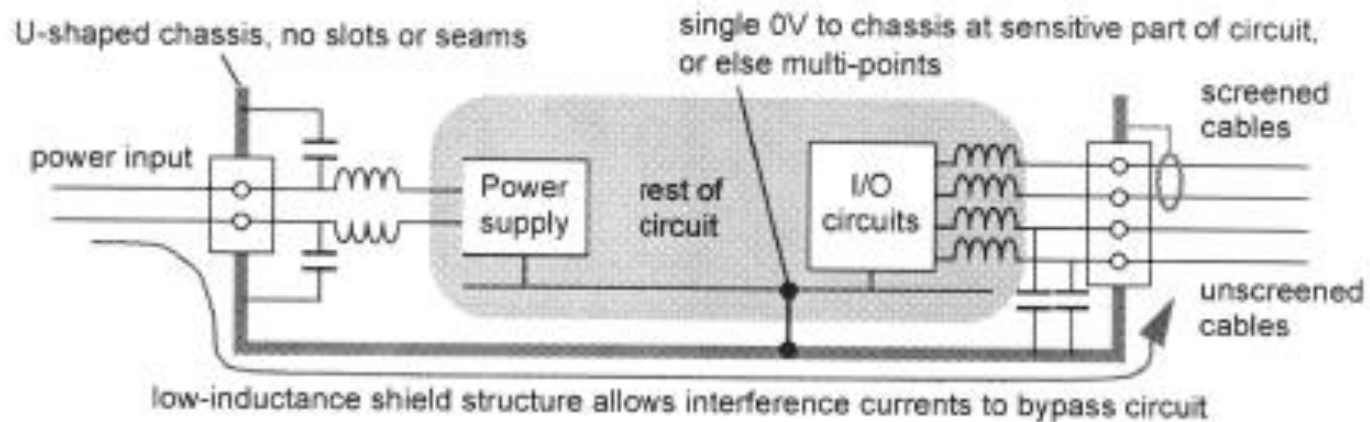

Figure 14.8 Shield metalwork as ground reference

Spegling i plan

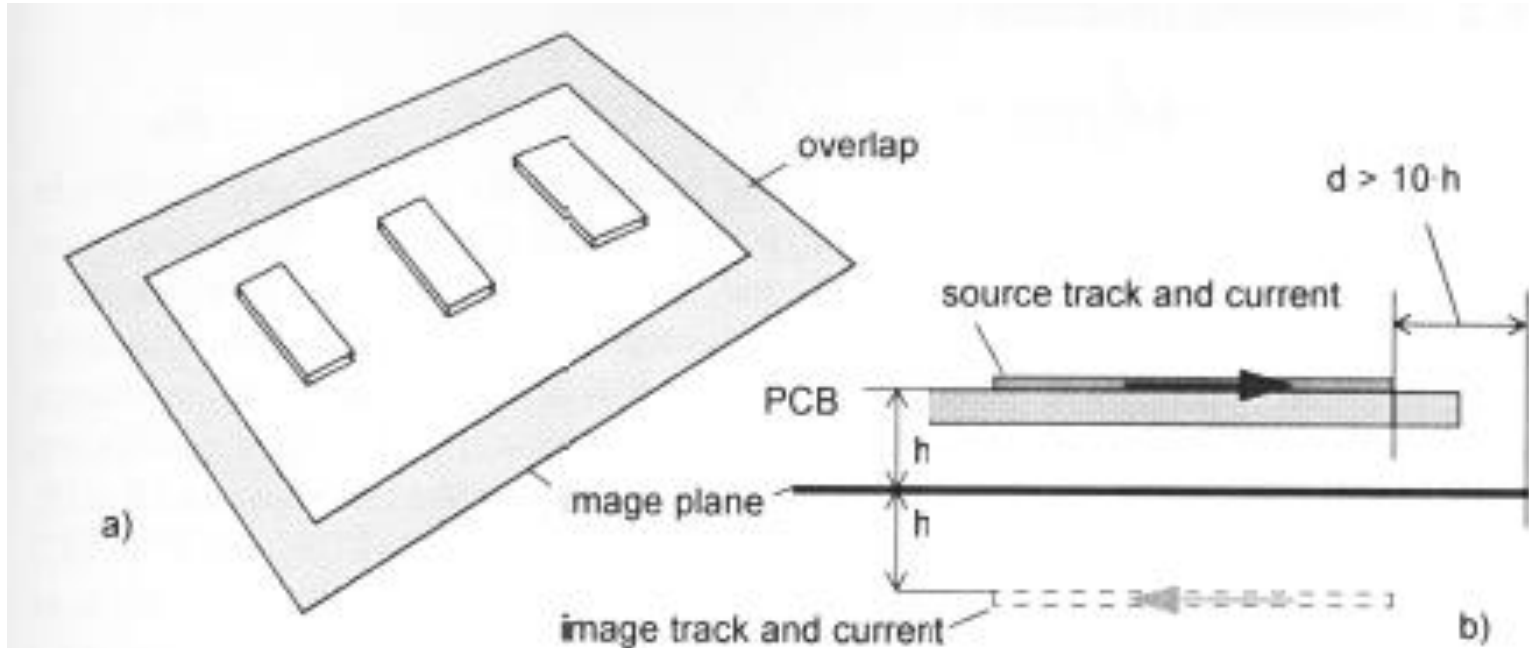
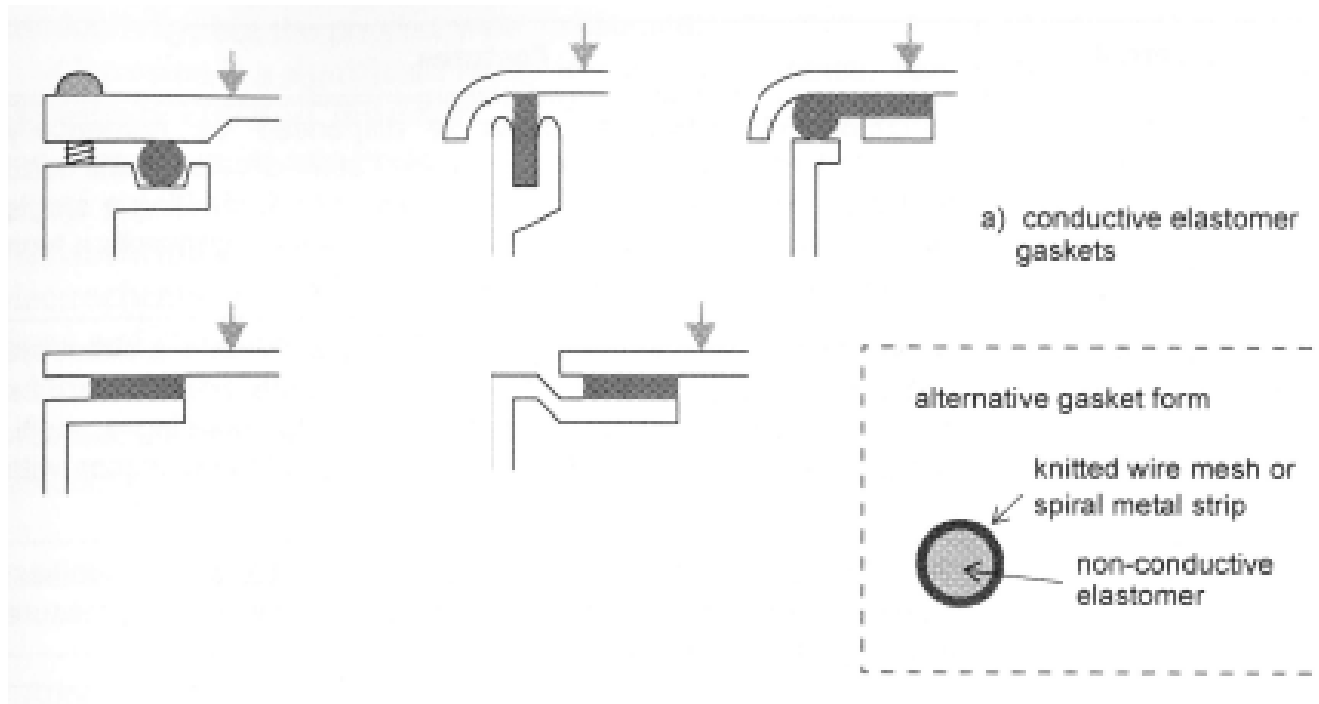
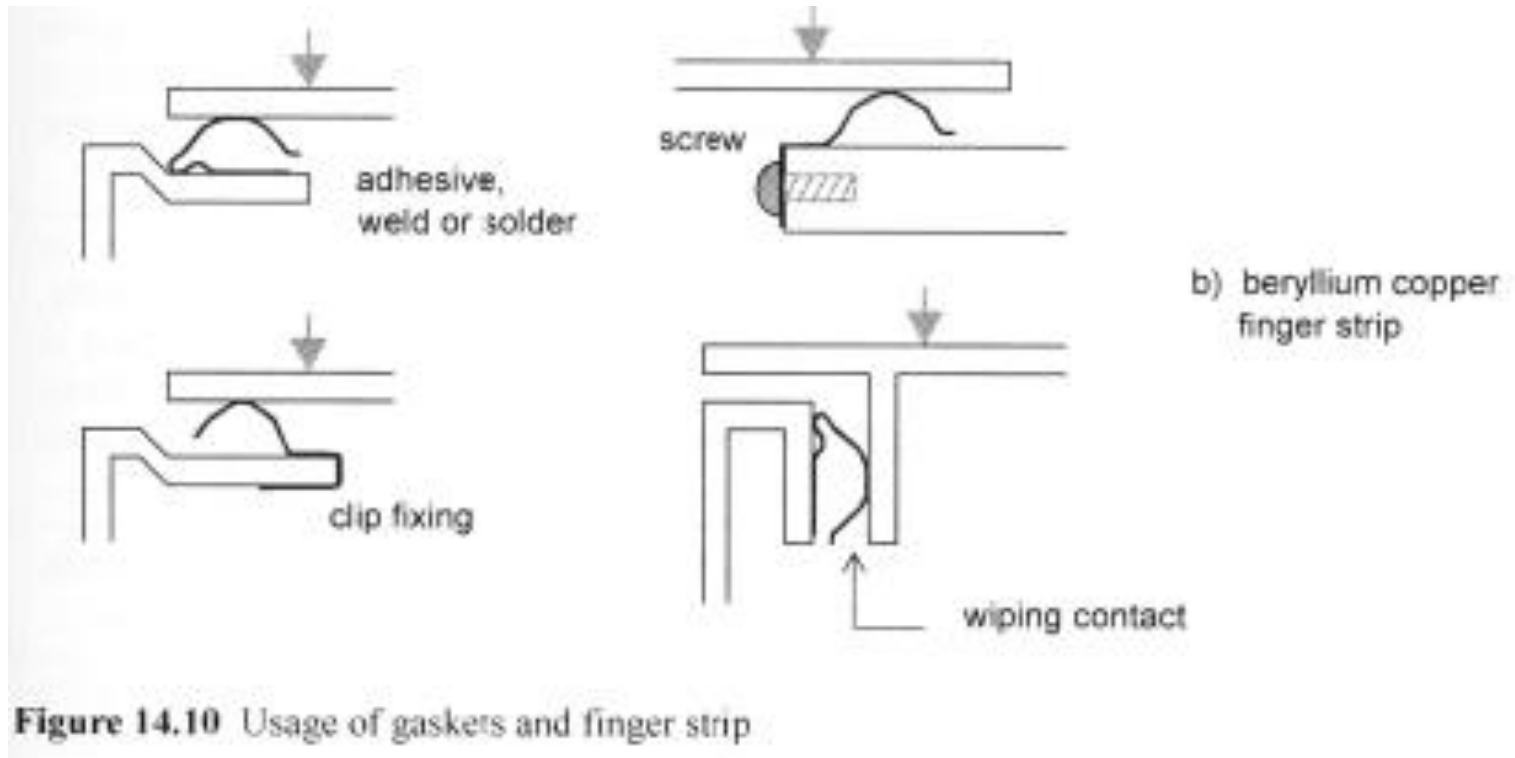

Figure 14.9 Image plane under a PCB

Packningar (gasket)



Fingrar



Skärma displayfönster

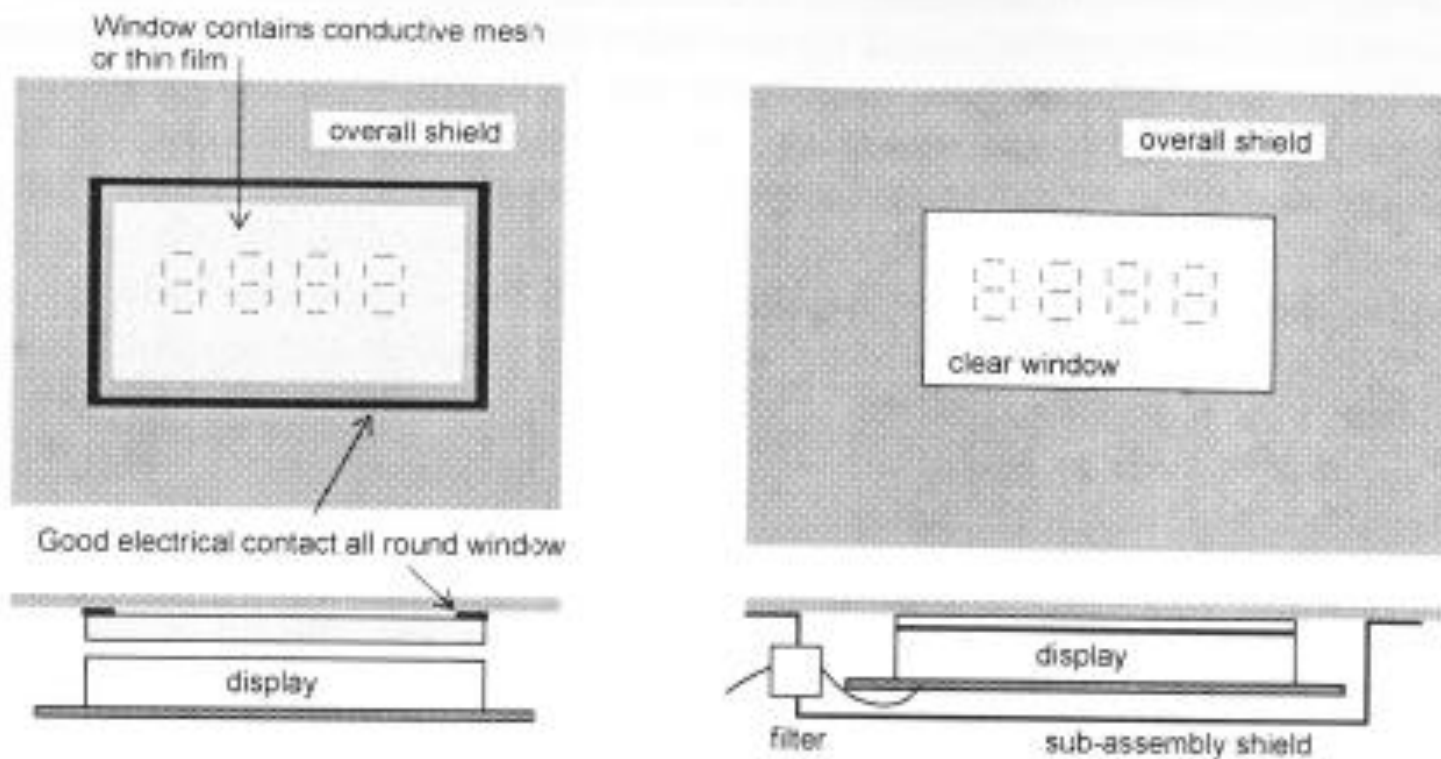

Figure 14.12 Alternative ways to shield a display window

Ventilationshål

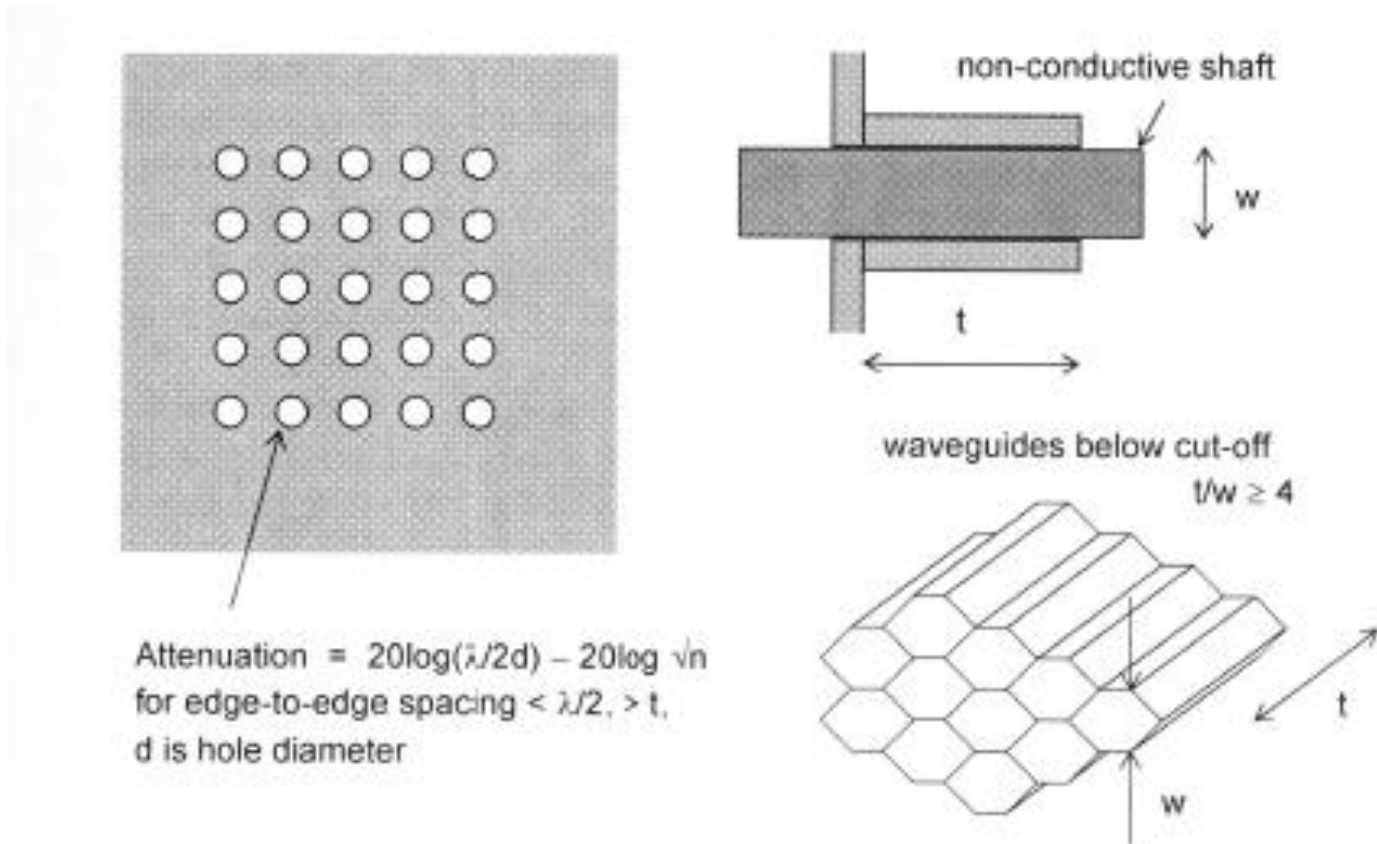

Figure 14.14 Mesh panels and the waveguide below cut-off

Skärma del av PCB

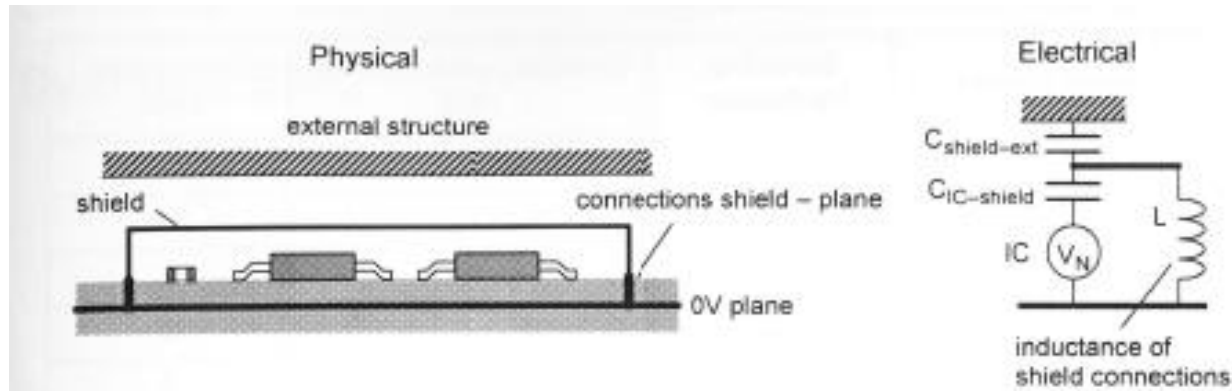

Figure 14.15 Equivalent circuit for E-field shield on a PCB

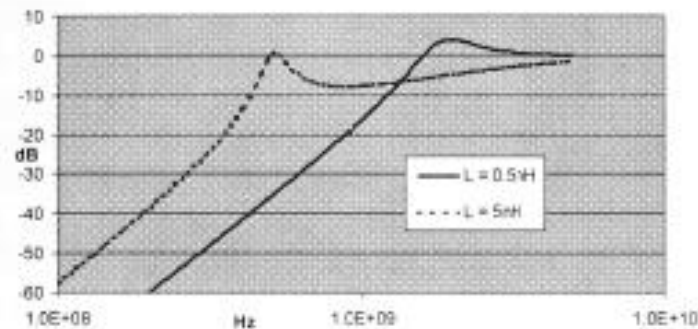

Figure 14.16 Attenuation through ϵ shield with mounting inductance L .

