

# IE1204 Digital Design Practice Exam Solutions

## 17 Analysis of Combinational Circuit

### Swedish:

1. Ta fram booleskt uttryck för kretsen nedan.
2. Rita K-map för kretsen med variabelordning som i figuren.
3. Förenkla uttrycket med hjälp av K-map.
4. Rita ny krets med enbart 2- och 3-ingångars NOR-grindar.

### English:

1. Derive the Boolean expression for the circuit below.
2. Draw a K-map for the circuit with variables as in the figure.
3. Simplify the expression using the K-map.
4. Draw a new circuit using only 2 and 3 input NOR gates.

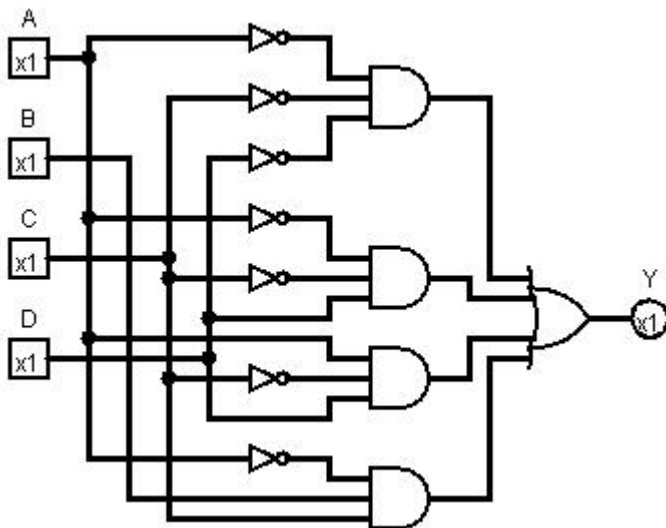

$$\bar{A}\bar{C}\bar{D} + \bar{A}\bar{C}D + A\bar{C}D + \bar{A}BC$$

$$\sim A \sim C \sim D + \sim A \sim C D + A \sim C D + \sim A B C$$

Use POS for NOR only (inverters are ok if you note that they can be made with a NOR)

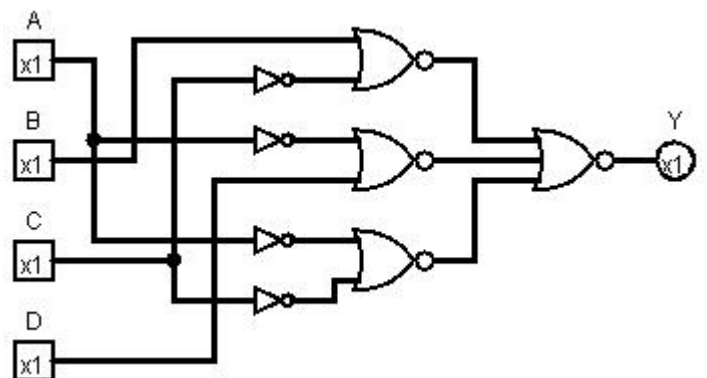
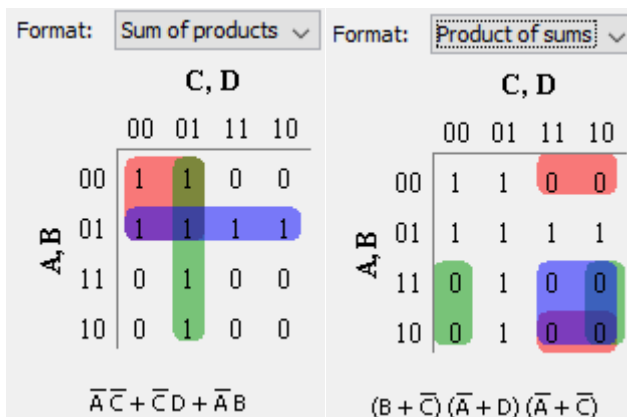

## 18 Design of Combinational Circuit

### Swedish:

Designa en kombinatorisk krets för  $Y=f(A, B, C, D)$  där

$Y = 1$  för alla udda tal utom de som är jämt delbara med 3

$Y = 0$  för alla udda tal jämt delbara med 3, utom 15

$Y = 0$  för alla jämna tal utom talet 0, och de som är jämt delbara med 3

$Y = 1$  för talet 0

$Y = x$  (don't care) för alla jämna tal delbara med 3, och för talet 15

1. Rita sanningstabellen.
2. Rita K-map för sanningstabellen med variabelordning som i figuren.
3. Uttnyttja  $x = \text{don't care}$ . Ta fram enklast möjliga booleska uttryck från K-map.
4. Rita en krets för uttrycket med enbart 2- och 3-ingångars NAND-grindar.

### English:

Design a combinational circuit for  $Y=f(A, B, C, D)$  where

$Y = 1$  for all odd numbers except those evenly divisible by 3

$Y = 0$  for all odd numbers evenly divisible by 3, except 15

$Y = 0$  for all even numbers except the number 0, and those evenly divisible by 3

$Y = 1$  for the number 0

$Y = x$  (don't care) for all even numbers evenly divisible by 3, and number 15

1. Draw the truth table.
2. Draw a K-map for the truth table with variables as in the figure..
3. Use  $x = \text{don't care}$ . Derive simplest possible Boolean expression from the K-map.
4. Draw a circuit for the expression using only 2 and 3 input NAND-gates.

	CD = 00	01	11	10
AB = 00				
01				
11				
10				

Rita om K-map i dina inlämnade svar.

Redraw the K-map in your answer sheets.

(Answer on next page)

## 18 Design of Combinational Circuit

A	B	C	D	Y
0	0	0	0	1
0	0	0	1	1
0	0	1	0	0
0	0	1	1	0
0	1	0	0	0
0	1	0	1	1
0	1	1	0	x
0	1	1	1	1
1	0	0	0	0
1	0	0	1	0
1	0	1	0	0
1	0	1	1	1
1	1	0	0	x
1	1	0	1	1
1	1	1	0	0
1	1	1	1	x

Format:

		C, D			
		00	01	11	10
A, B	00	1	1	0	0
	01	0	1	1	x
	11	x	1	x	0
	10	0	0	1	0

$\bar{A}\bar{B}\bar{C} + BD + ACD$

Format:

		C, D			
		00	01	11	10
A, B	00	1	1	0	0
	01	0	1	1	x
	11	x	1	x	0
	10	0	0	1	0

$(A + B + \bar{C})(\bar{B} + D)(\bar{A} + B + C)(\bar{A} + D)$

Use SOP for NAND only (inverters are ok if you note that they can be made with a NAND)

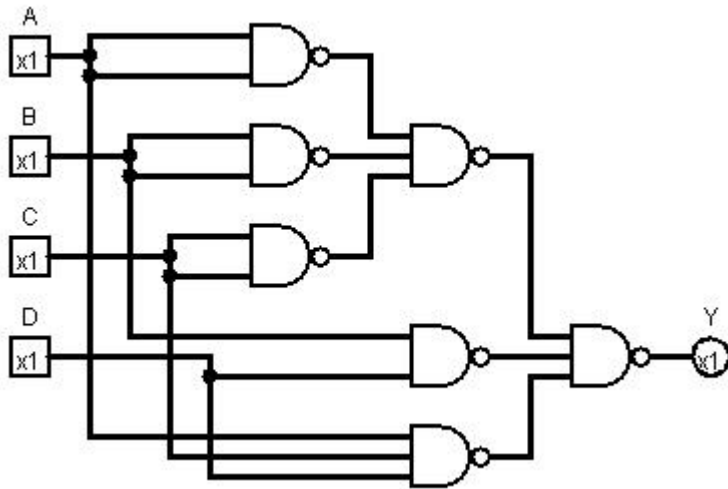

## 19 Analysis of FSM

**Swedish:** Analysera vad nedanstående tillståndsmaskin (FSM) utför.

1. Ta fram Boolska uttryck för nästa tillstånd.
2. Rita tillståndstabell.
3. Rita tillståndsdigram.

**English:** Analyze the state machine (FSM) below.

1. Derive Boolean expressions for next state.
2. Draw a state table.
3. Draw a state diagram.

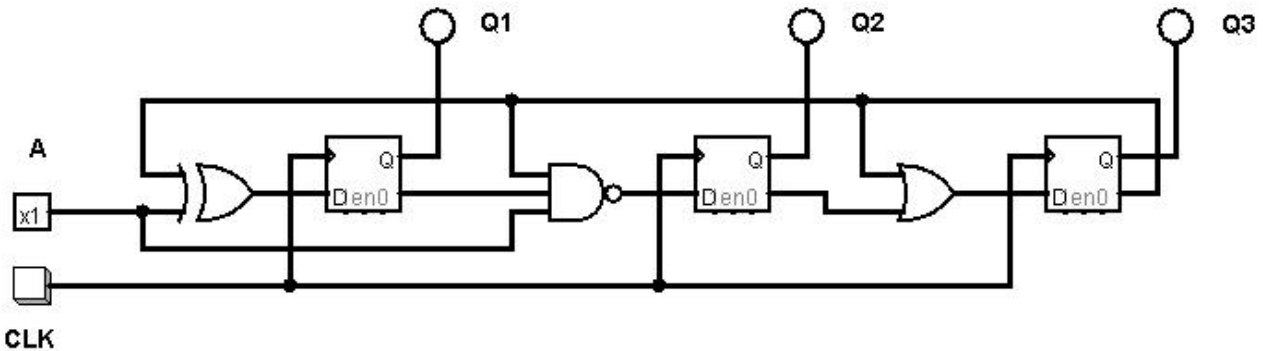

$$Q3+ = \overline{Q3} + \overline{Q2}$$

$$Q2+ = \overline{Q3} \cdot \overline{Q1} \cdot A = Q3 + Q1 + \overline{A}$$

$$Q1+ = \overline{Q3} \oplus A = Q3 \cdot A + \overline{Q3} \cdot \overline{A}$$

Present state			Next state A = 0			Next state A = 1		
Q3	Q2	Q1	Q3+	Q2+	Q1+	Q3+	Q2+	Q1+
0	0	0	1	1	1	1	0	0
0	0	1	1	1	1	1	1	0
0	1	0	1	1	1	1	0	0
0	1	1	1	1	1	1	1	0
1	0	0	1	1	0	1	1	1
1	0	1	1	1	0	1	1	1
1	1	0	0	1	0	0	1	1
1	1	1	0	1	0	0	1	1

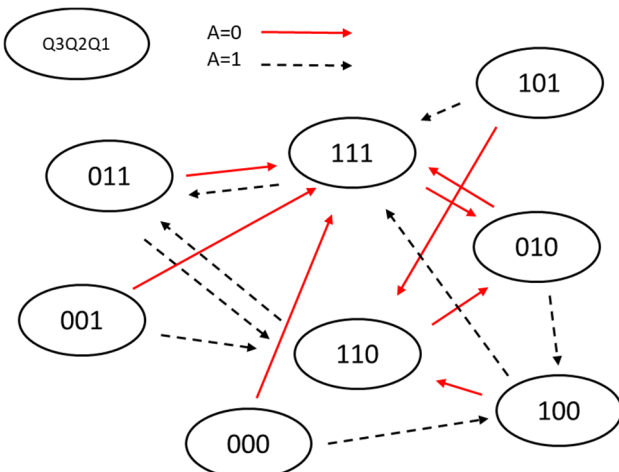

## 20 Design of FSM

**Swedish:** Konstruera en tillståndsmaskin (FSM) enligt tillståndsdigrammet nedan.

1. Rita tillståndstabell.
2. Ta fram K-map för nästa tillstånd och utsignal.
3. Ta fram minimerade uttryck för nästa tillstånd och utsignal.
4. Rita kretsschema för en FSM med DFFs och vilka grindar som helst.

**English:** Design a state machine (FSM) according to the state diagram below.

1. Draw a state table.
2. Derive K-maps for next state and output.
3. Derive minimized expressions for next state and output.
4. Draw the FSM circuit diagram with DFFs and any gates.

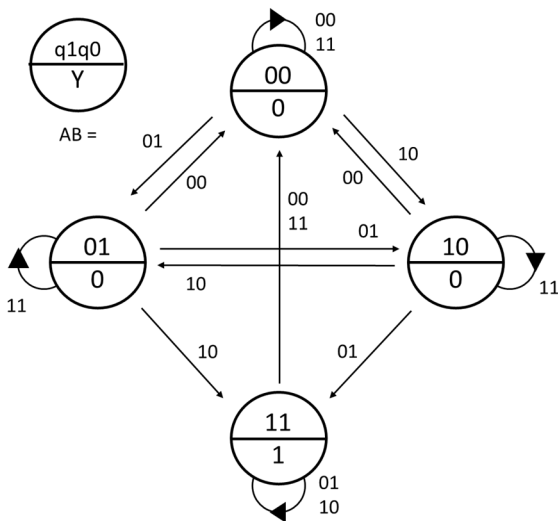

q1q0 = 00	AB =			
	00	01	11	10
00				
01				
11				
10				

Rita om K-map i dina inlämnade svar.

Redraw the K-map in your answer sheets.

Present state		Next state								Out
		AB = 00		AB = 01		AB = 11		AB = 10		
q1	q0	q1+	q0+	q1+	q0+	q1+	q0+	q1+	q0+	Y
0	0	0	0	0	1	0	0	1	0	0
0	1	0	0	1	0	0	1	1	1	0
1	1	0	0	1	1	0	0	1	1	1
1	0	0	0	1	1	1	0	0	1	0

q1+	AB=				
q1q0	00	01	11	10	
00	0	0	0	1	
01	0	1	0	1	
11	0	1	0	1	
10	0	1	1	0	

q0+	AB=				
q1q0	00	01	11	10	
00	0	1	0	0	
01	0	0	1	1	
11	0	1	0	1	
10	0	1	0	1	

(K-map not needed for Y)

Output:

Format:

		A, B			
		00	01	11	10
q1, q0	00	0	0	0	1
	01	0	1	0	1
	11	0	1	0	1
	10	0	1	1	0

$\overline{q1} \overline{A} \overline{B} + q0 \overline{A} B + q0 A \overline{B}$   
 $+ q1 q0 B$

Output:

Format:

		A, B			
		00	01	11	10
q1, q0	00	0	1	0	0
	01	0	0	1	1
	11	0	1	0	1
	10	0	1	0	1

$\overline{q0} \overline{A} B + \overline{q1} q0 A + q1 \overline{A} B$   
 $+ q1 A \overline{B}$

$$Y = q1 \cdot q0$$

