

Energy transfer with a resistor

An emf E_1 with a higher voltage can charge an other emf E_2 with a lower voltage if you connect them together with a current limiting resistor. $E_1 > E_2$.

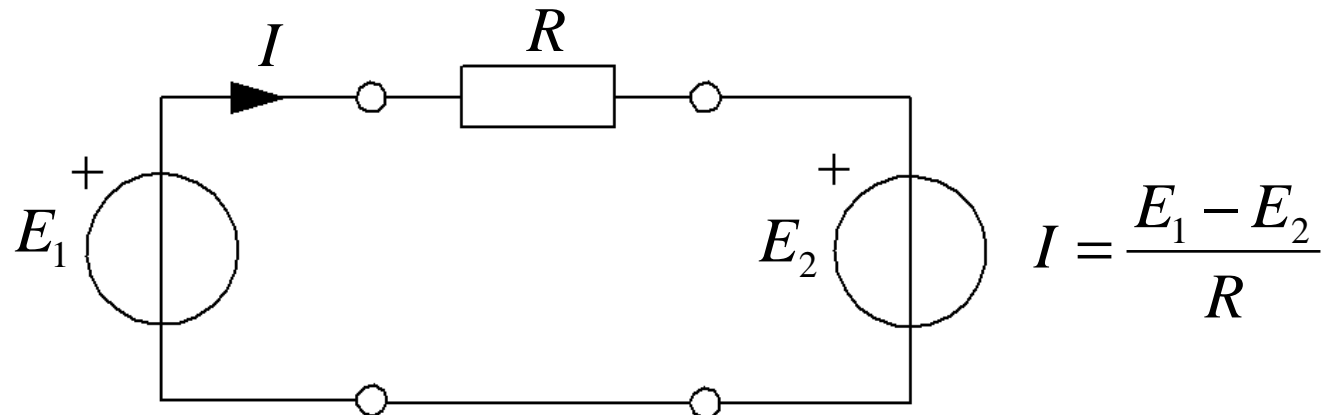

The delivered energy $W_1 = E_1 It$ \longrightarrow $W_R = RI^2 t$ \longrightarrow Stored energy $W_2 = E_2 It$

During charging, there becomes heat losses in R .

Energy transfer with an inductor

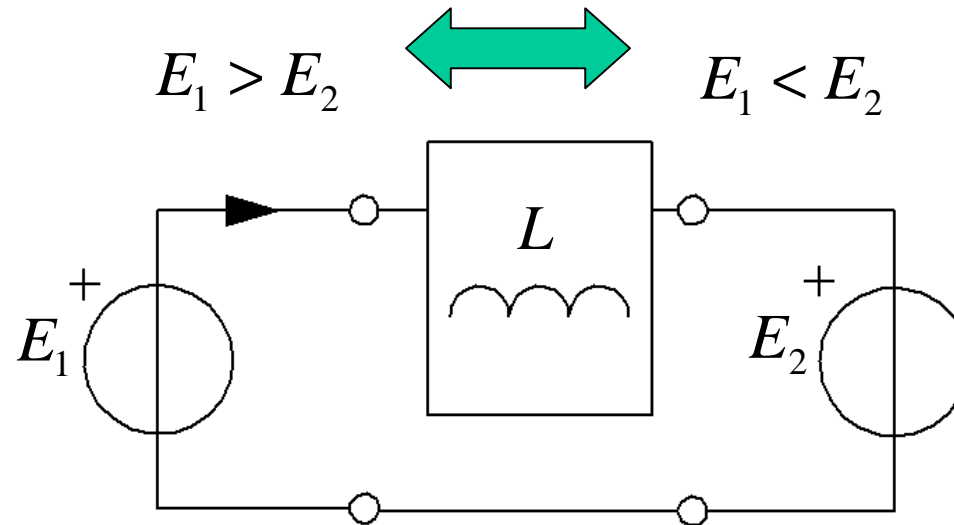

With an inductor one can transfer energy from a larger emf to a smaller, $E_1 > E_2$, **Step Down**, but also from a smaller emf to a larger, $E_1 < E_2$, **Step Up**. This in theory is completely without losses.

Step Up

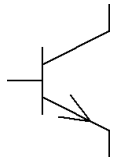
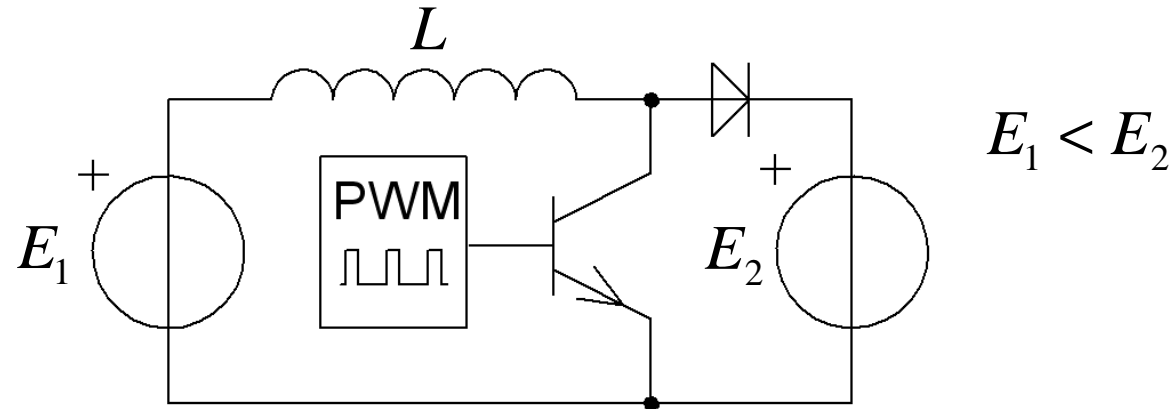

• Transistor

Pulse width modulation



• PWM-unit

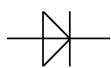

• Diode

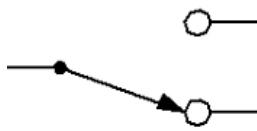

Transistor and diode acts together as a switch controlled by the PWM unit.

$$E_1 < E_2$$

Step Up

D: 0%

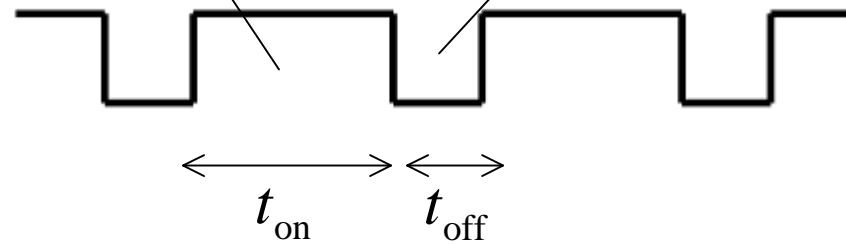
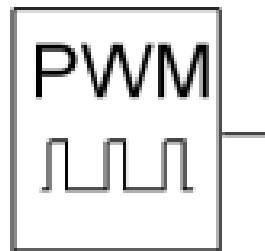
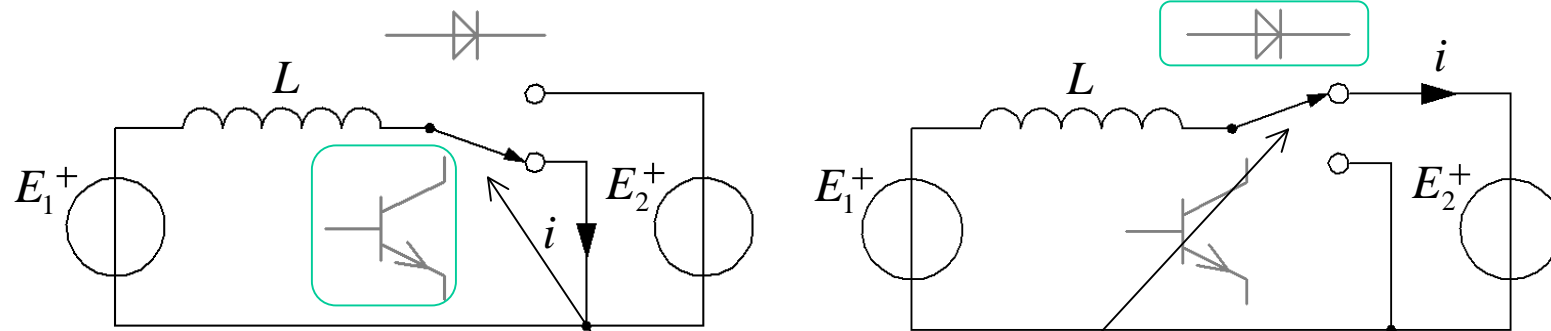

• DutyCycle D :

$$D = \frac{t_{on}}{t_{on} + t_{off}}$$

The coil current inertia

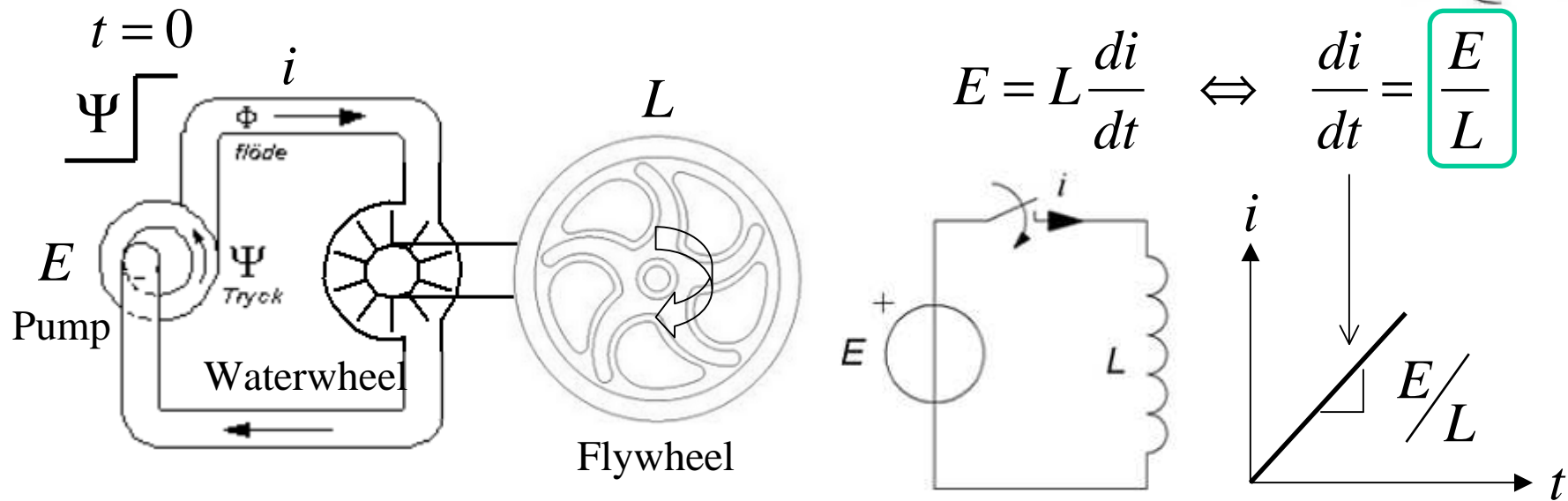

The inductor has **current-inertia**. The current can not change immediately. A fluid analogy: The inductor is a water mill with a flywheel.

Energy transfer with an inductor

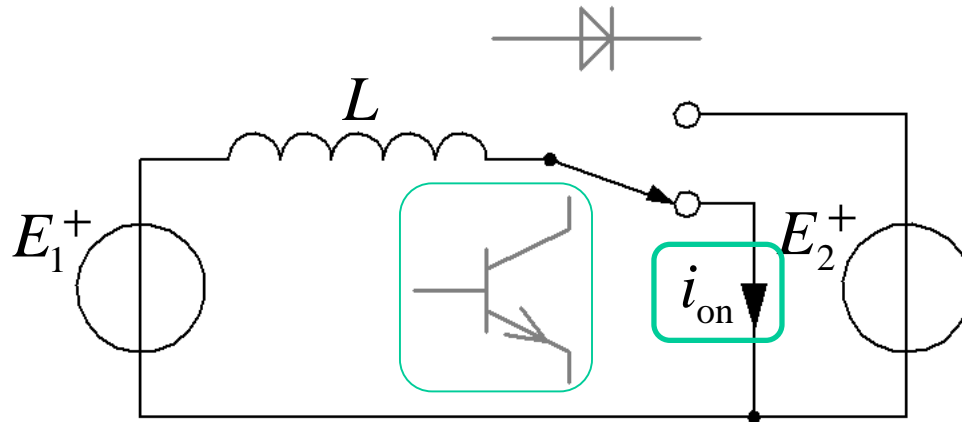

Let E_1 drive an increasing current through L during t_{on} . The current then reaches I_{max} .

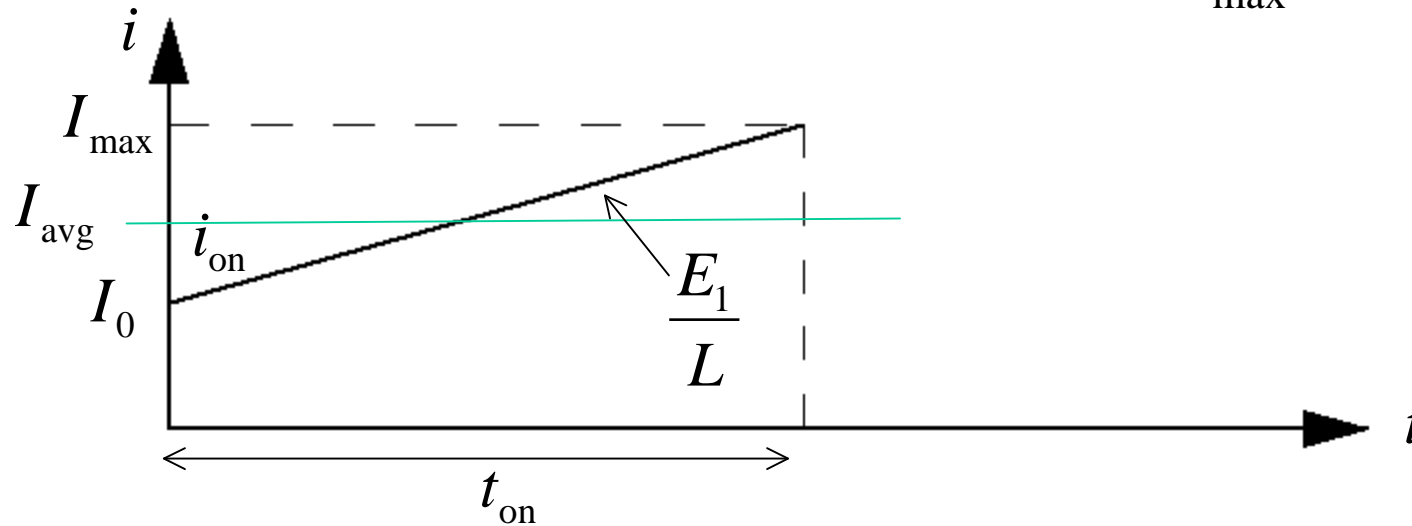

Energy transfer with an inductor

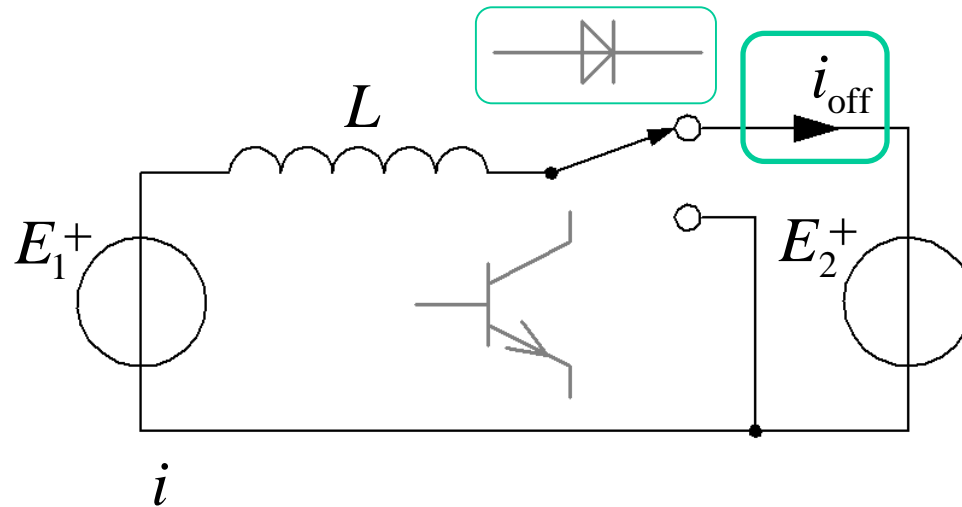

switch the inductor so that L now continues the current through E_2 . $E_2 > E_1$ means that the current will be decreasing. It will reach I_0 again after time t_{off} .

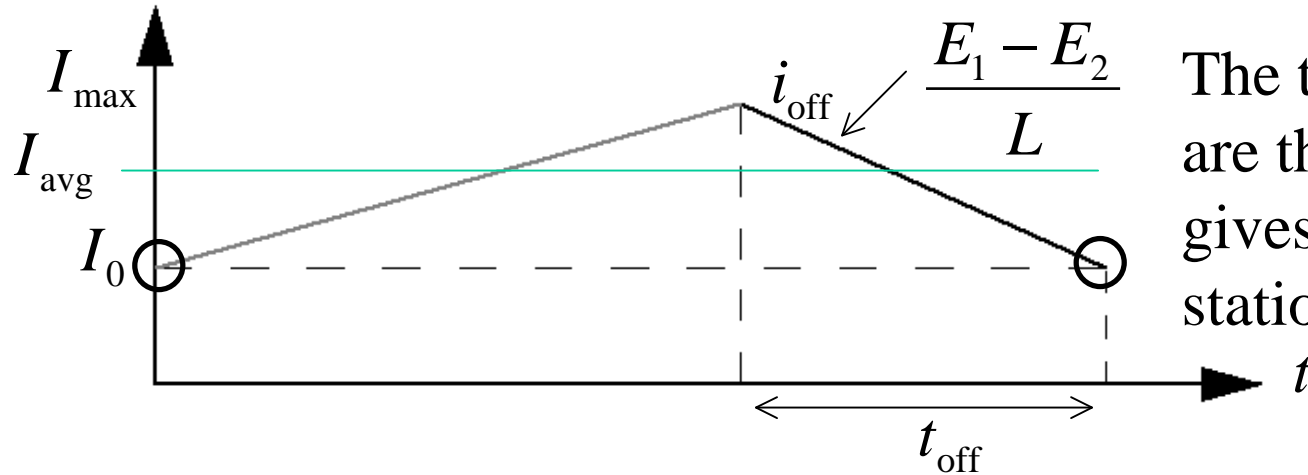

The times t_{on} , t_{off} are those that gives us a stationary plot.

Energy transfer with an inductor

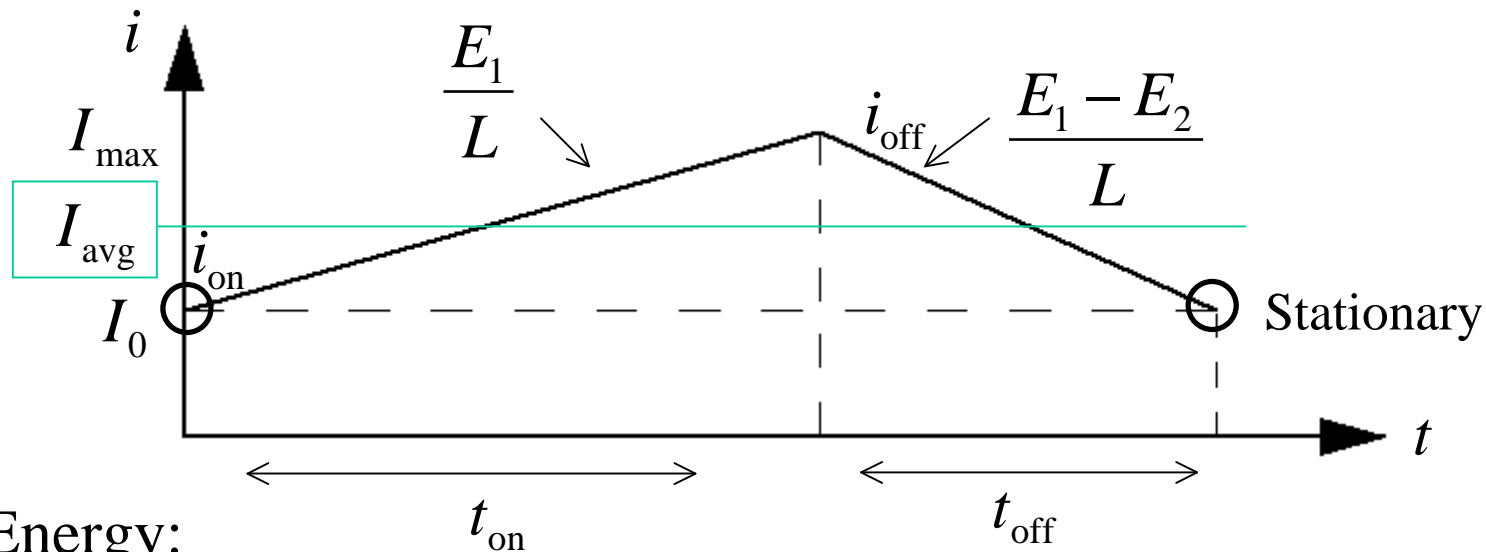

Energy:

$$W_{on} = E_1 \cdot I_{avg} \cdot t_{on} \quad W_{off} = (E_1 - E_2) \cdot I_{avg} \cdot t_{off} \quad W_{on} = W_{off}$$

$$\frac{E_2}{E_1} = \frac{t_{on} + t_{off}}{t_{off}} = \frac{1}{1 - D} \quad E_2 = E_1 \cdot \frac{1}{1 - D}$$

5V \rightarrow 50V ?

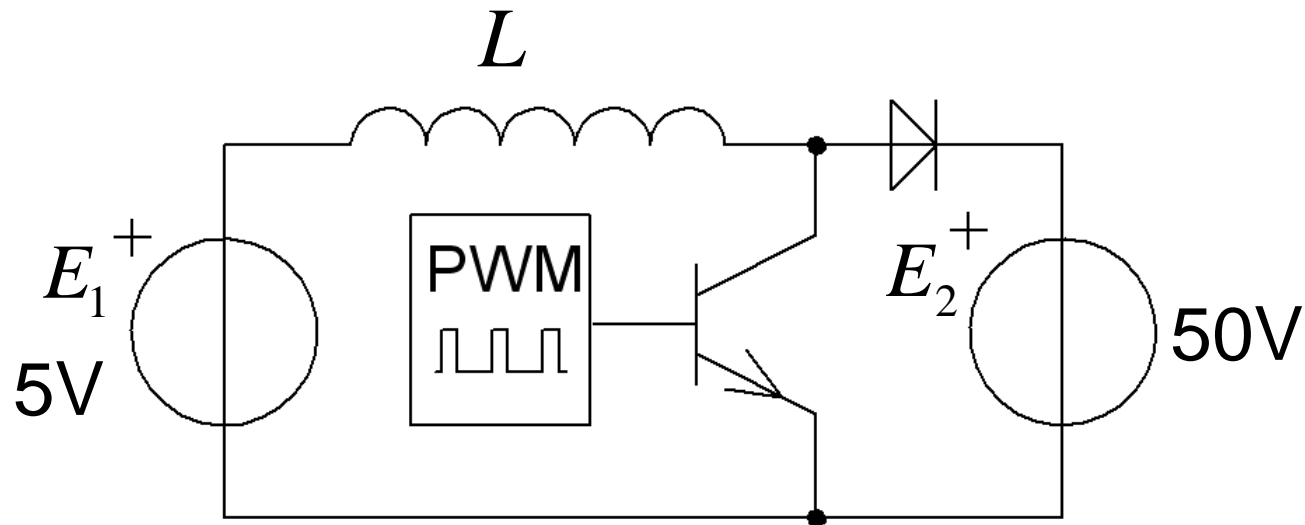

$$E_2 = E_1 \cdot \frac{1}{1-D} \Rightarrow D = 1 - \frac{E_1}{E_2} = 1 - \frac{5}{50} = 90\%$$

Resistiv load?

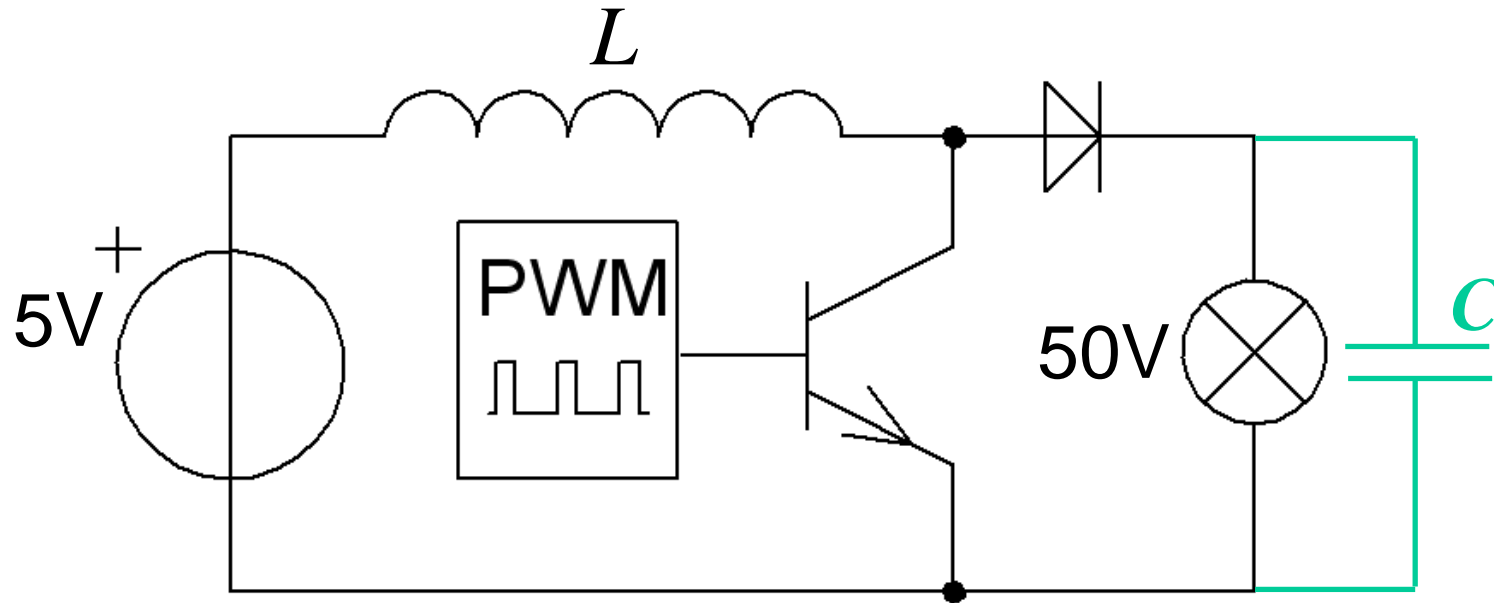

The current to the load will flow intermittently only during t_{off} , so the voltage needs to be smoothed with a capacitor C .

(What is a diode?)

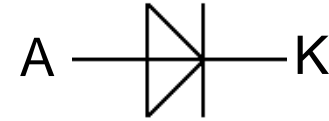

Semiconductor diode

Symbol and characteristic

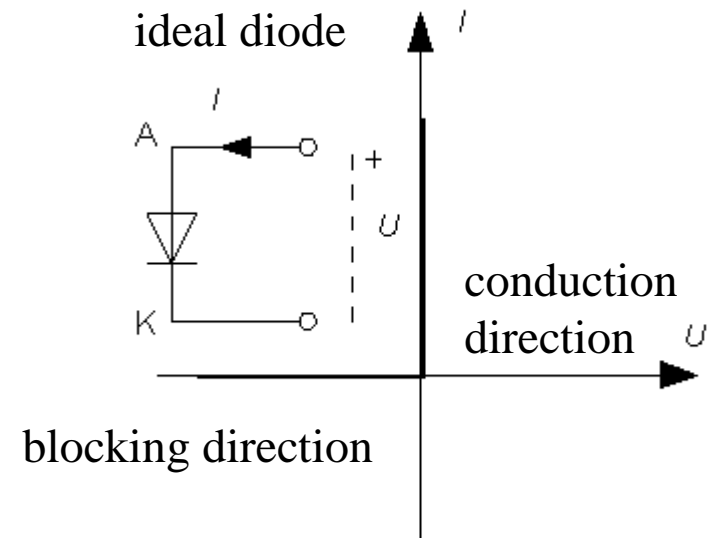

Fluid Analogy

check valve

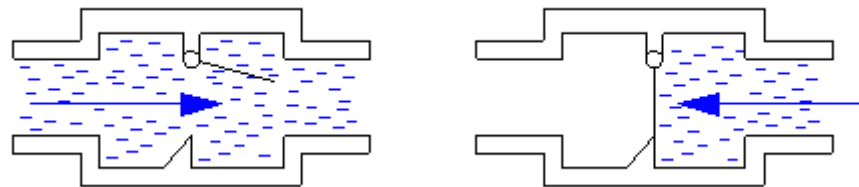

(What is a transistor?)

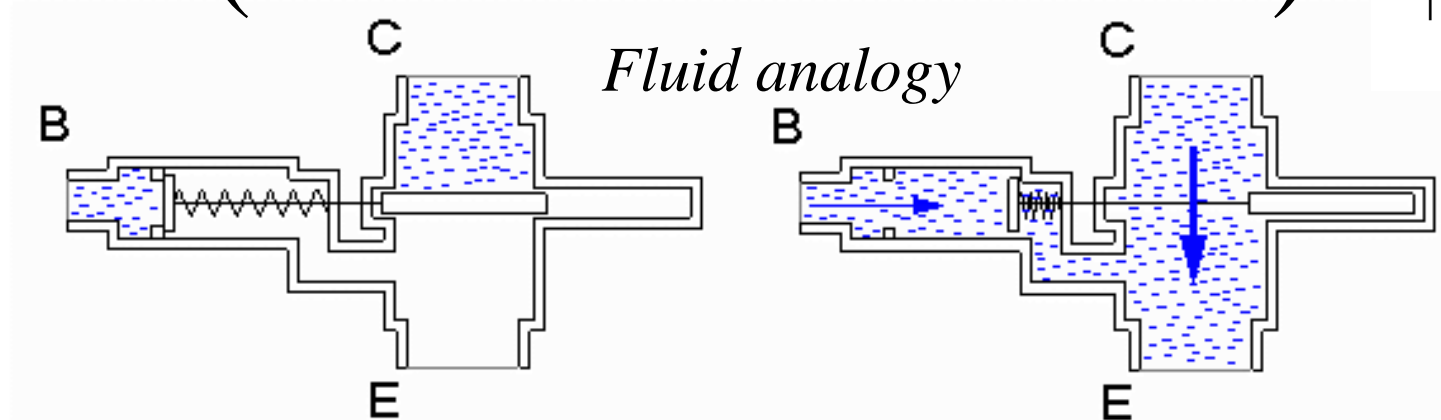
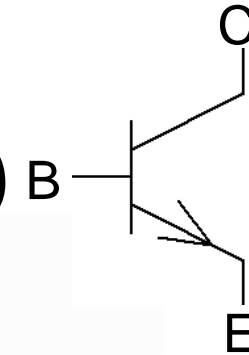

The classic bipolar transistor, is earlier development than the MOS transistor.
 A small "base current" I_B can control up to 100 times (h_{FE}) bigger
 "collector current" I_C .

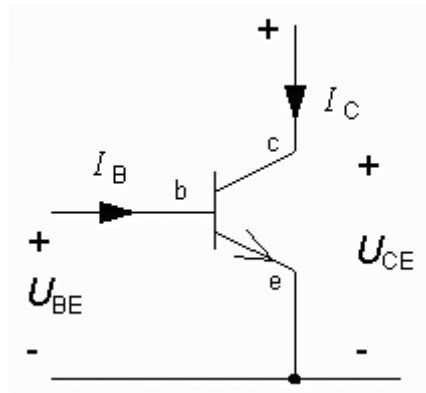

$$h_{FE} = \frac{I_C}{I_B}$$

$$h_{FE} \approx 100$$

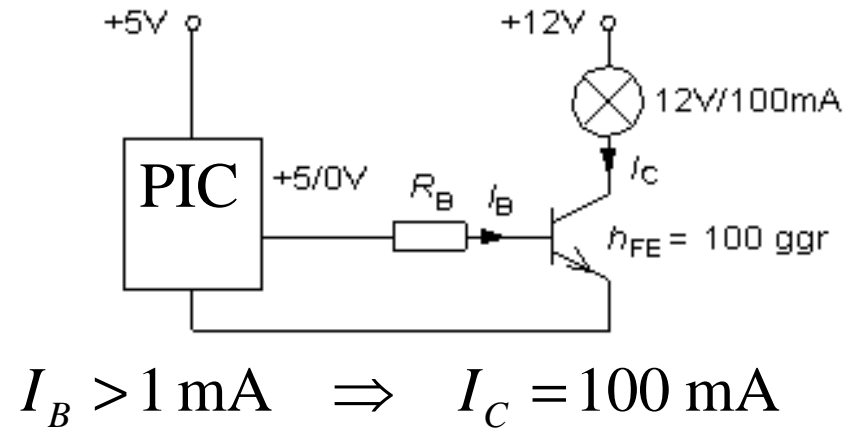

Practical dimensioning?

It is simple to set up the Step-up converter's output voltage with the DutyCycle D ! This we do at the lab.

In practice it is much more *difficult*. An electronics engineer is faced with many questions:

At what current "saturate" the coil iron core? How big internal resistance has the inductor? How big are the load variations? What values to L and C and f should be chosen? It is common to simulate the circuit with more realistic component models than what we use here.

LT:s App note has the title "**Switching Regulators for Poets**"

A problem is that while everyone agrees that working switching regulators are a good thing, everyone also agrees that they are difficult to get working.

Unfortunately, switching regulators are one of the most difficult linear circuits to design. Mysterious modes, sudden, seemingly inexplicable failures, peculiar regulation characteristics and just plain explosions are common occurrences. Diodes conduct the wrong way. Things get hot that shouldn't. Capacitors act like resistors, fuses don't blow and transistors do. The output is at ground, and the ground terminal shows volts of noise. ...

Jim Williams

Jim Williams at lab



William Sandqvist william@kth.se

Simulation

$D = 86\%$
Startup
Sequence
0...1ms

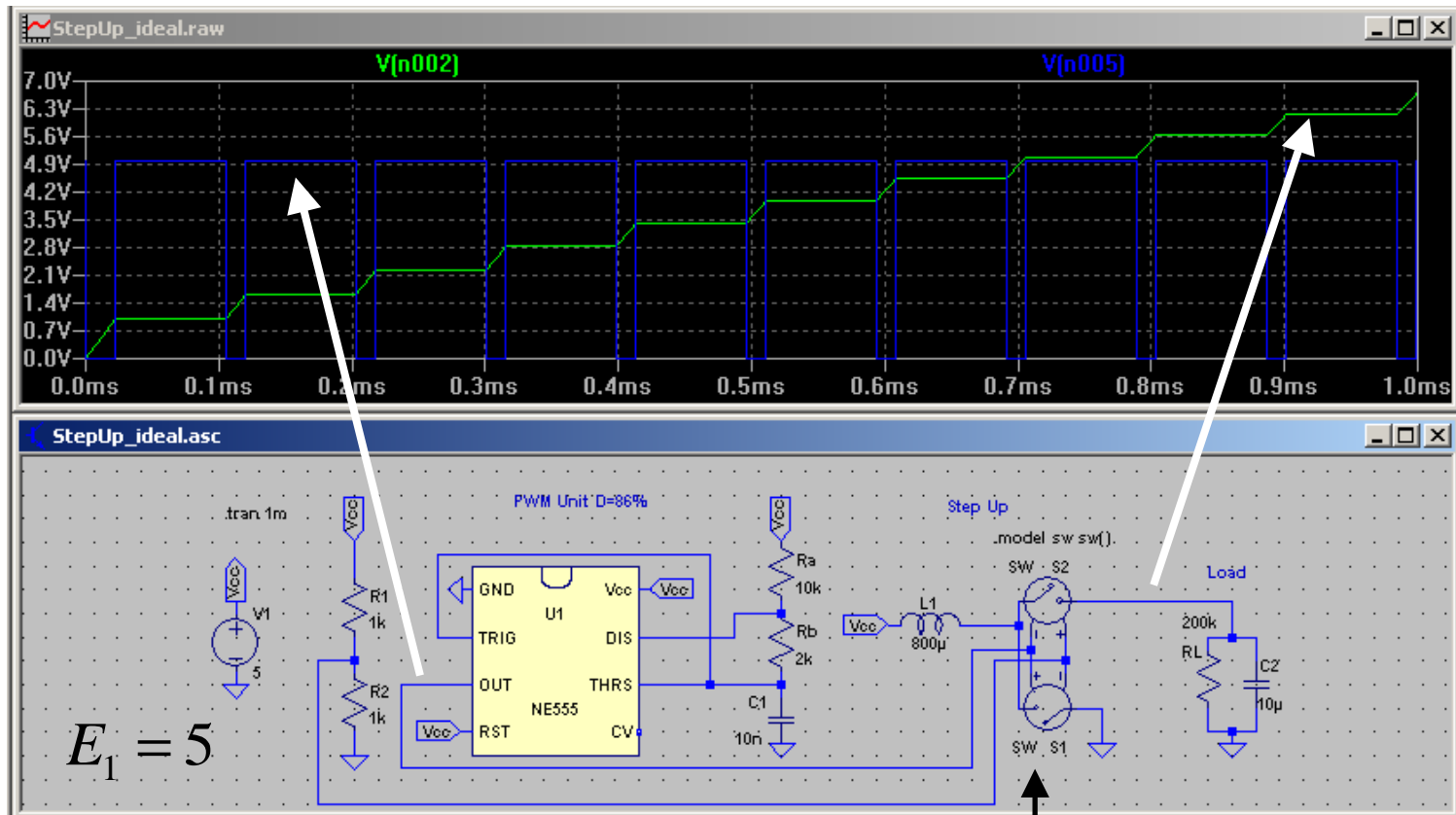

The voltage is stepping upwards...

Simulation with an ideal switch

Simulation

$$E_2 \approx 30$$

Stationary at
100 ms

$$E_1 = 5V$$

$$E_2 \approx 30V$$

$$D = 86\%$$

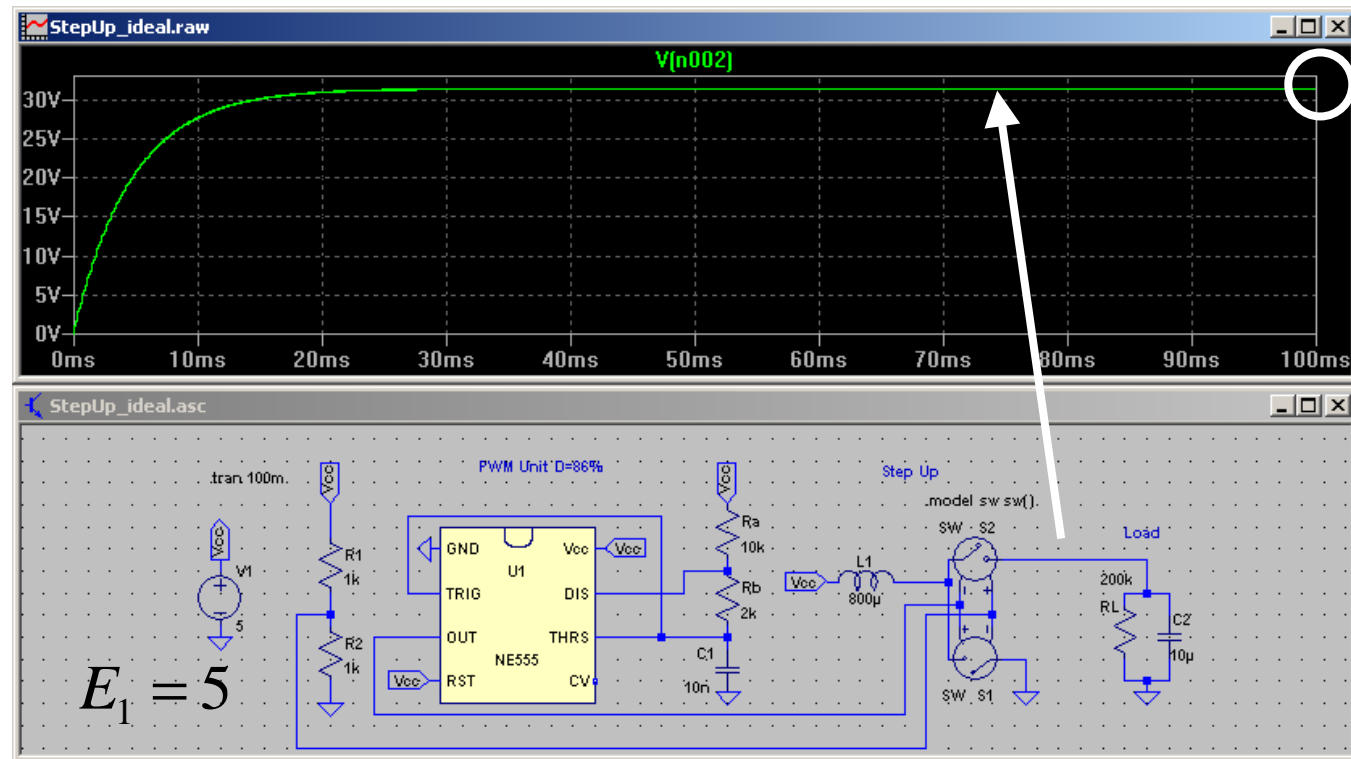

William Sandqvist william@kth.se