

IE1206 Embedded Electronics

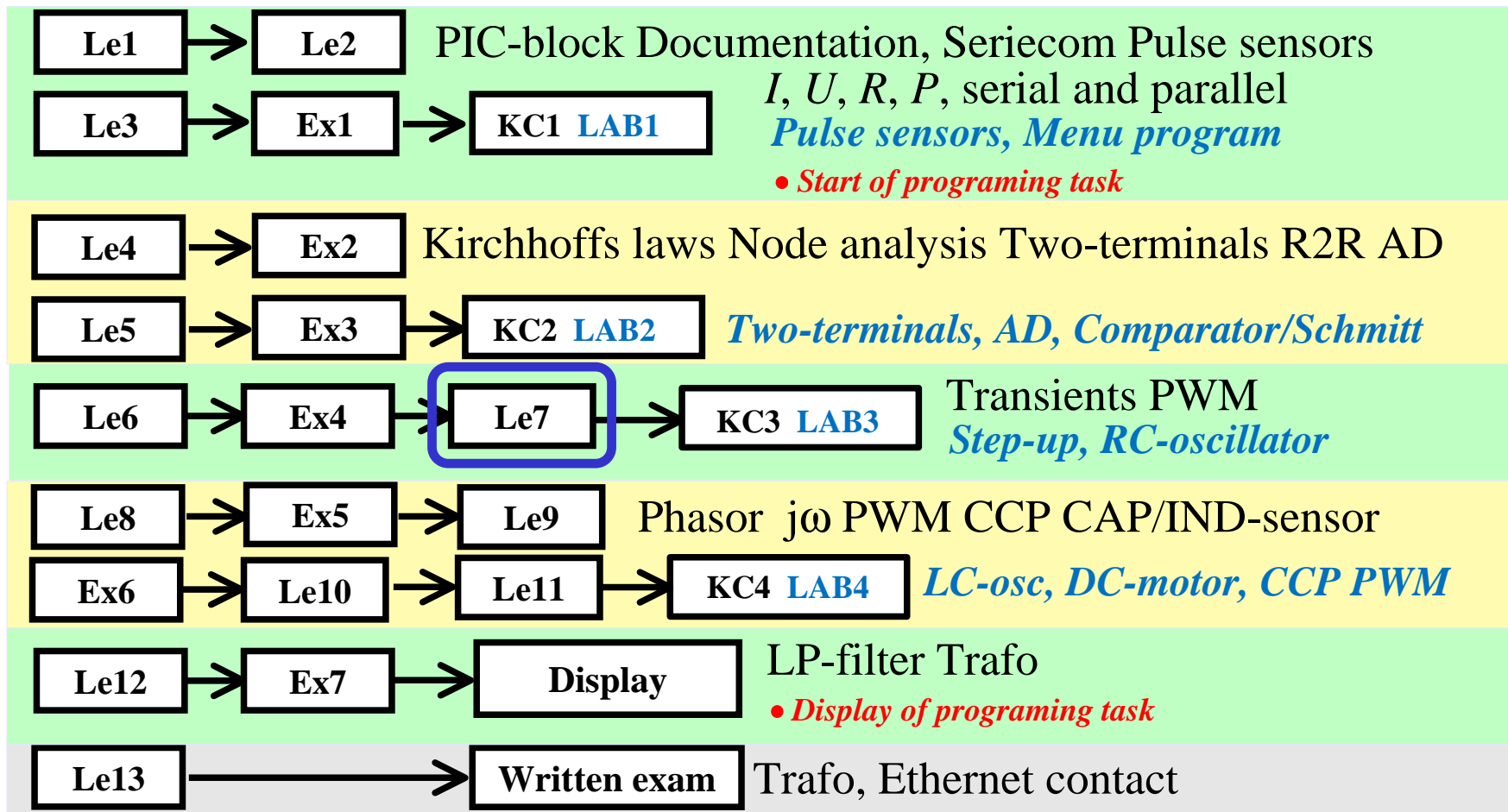

Magnetism?

What do you remember about magnetism and electromagnetism?

Permanent magnets

Each magnet has a magnetic field. The field direction is defined from the North Pole and into the South Pole.

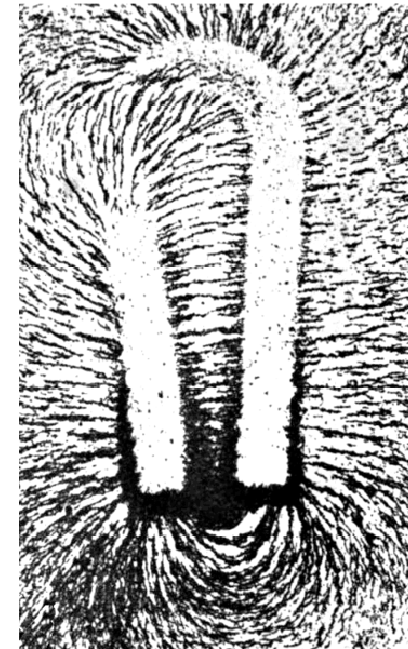
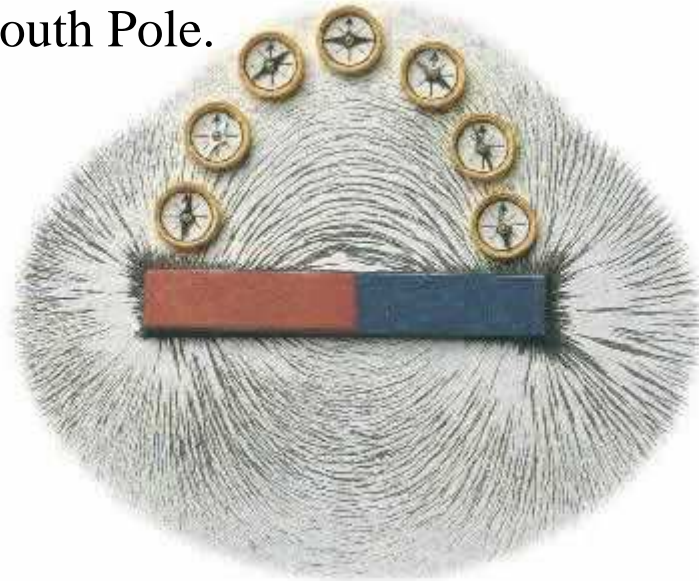

Field, lines of force, can be illustrated with iron filings or with spaced compass needles. Nowadays there are also "Magnetic Field Viewer Film".



The force between magnets

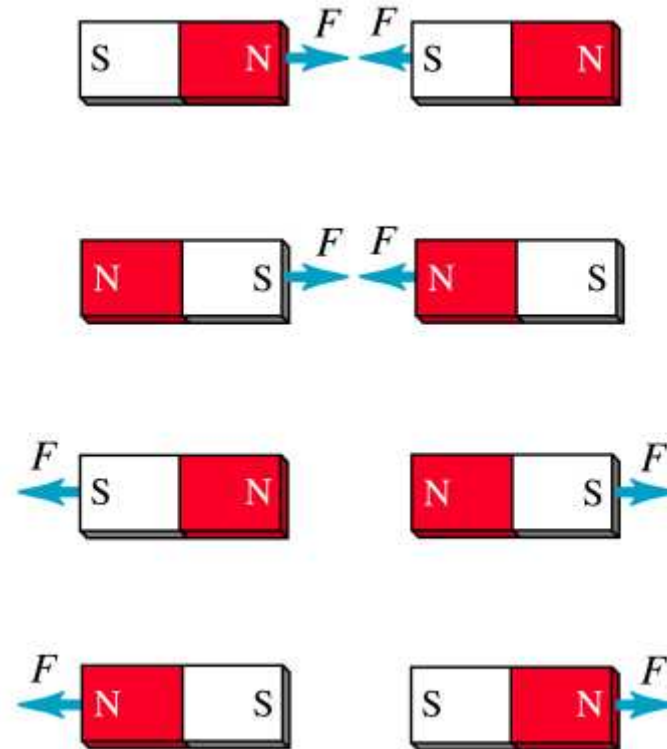

You probably know the rules for the force between magnets.

A magnet is divided into three pieces

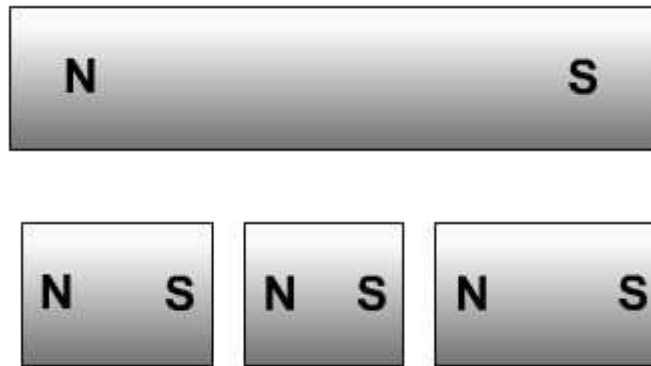

If a magnet is cut into smaller parts, each part becomes a complete magnet with its own North Pole and South Pole.

Magnetic domains



**Domains Before
Magnetization**



**Domains After
Magnetization**

A magnetic material consists of a large number of "elementary magnets". Typically, these are disordered and therefore makes the material non-magnetic. If the material is magnetized elementary magnets are arranged so that they work together making the material magnetic.

Flux and flux density

The basic magnetic quantity is the magnetic flux ϕ with the unit Weber [Wb].

Flux can be seen as the "total amount of force lines".

The magnetic field is unevenly distributed in space, the flux density $B = \Delta\phi/\Delta A$ [Wb/m²] is a measure of the local field strength.

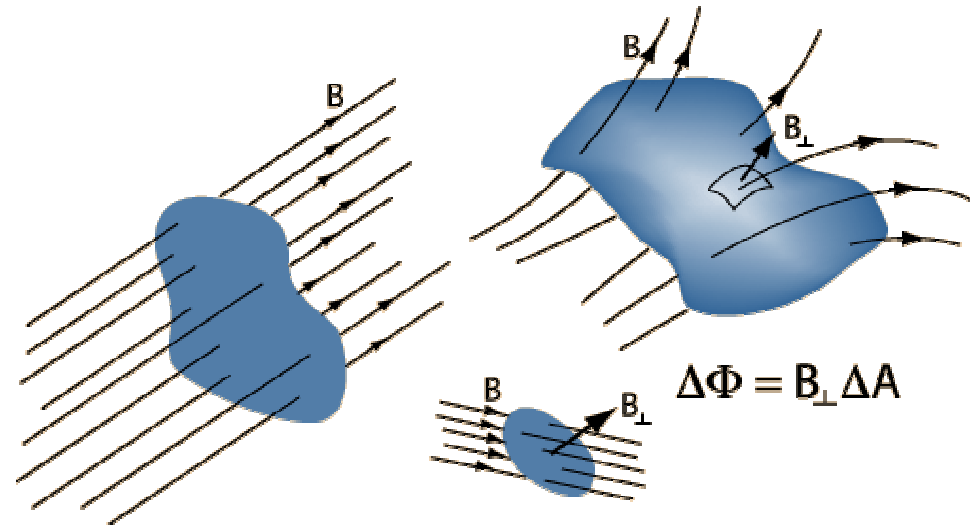

The magnetic force lines follow the "path of least resistance" and a material's magnetic conductivity is called **permeability**.

Rule: Force lines are closed, and can never cross each other or go into another.

Field images between poles

Path of least resistance - shorter route to the second magnet south poles than to its own!

The magnets attract each other.

Force lines may not cross each other.

The magnets repel each other.

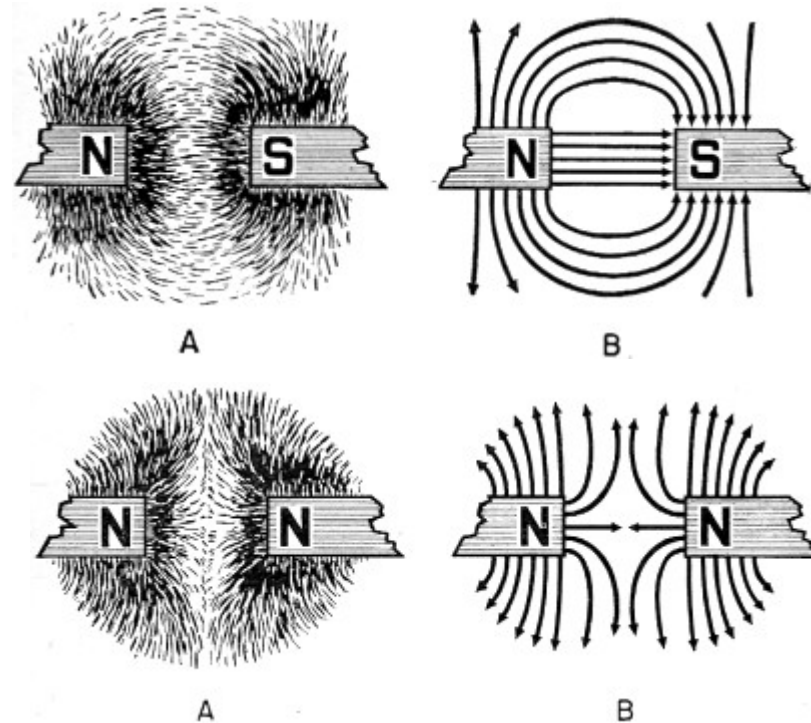

Figure: Electricity - Basic Navy Training Courses
U.S. GOVERNMENT PRINTING OFFICE 1945

Quick question? Permanent magnets

(Ex. 9.5) Draw the magnetic force lines in the figure.
Mark with arrows the direction of the field. Discuss with
your nearest bench neighbors.



Quick question! Permanent magnets

(Ex. 9.5) Draw the magnetic force lines in the figure.
Mark with arrows the direction of the field.

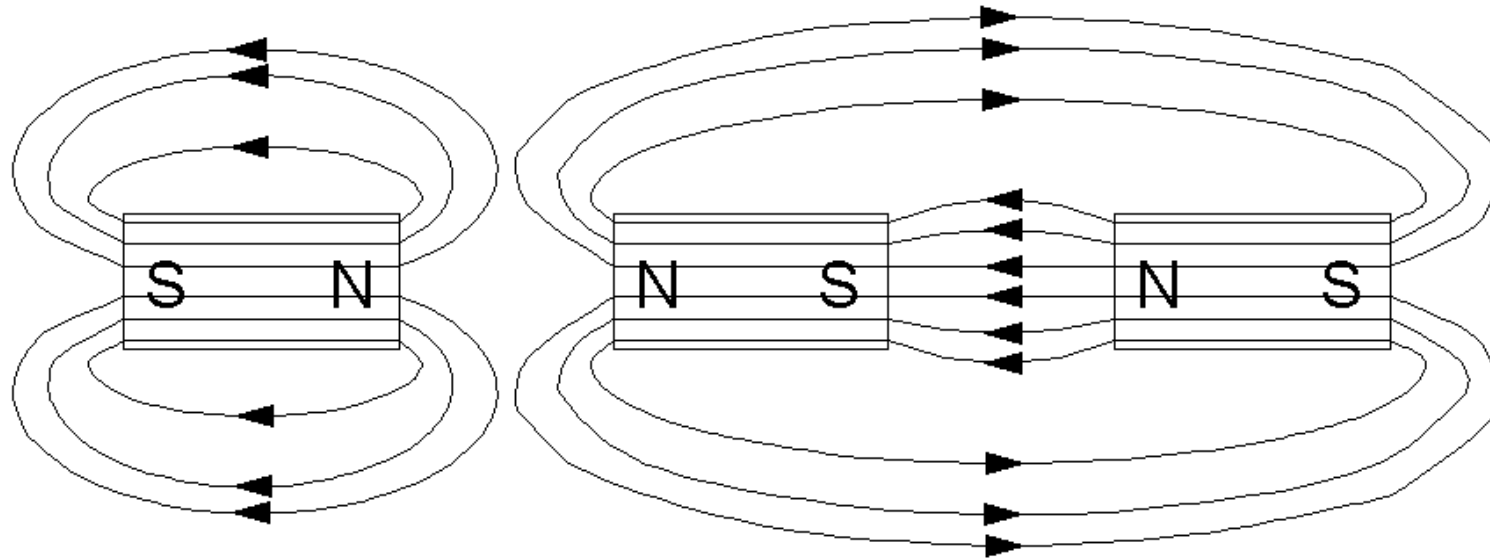

Permeability μ

"Magnetizable" materials such as iron and nickel has good ability to support the formation magnetic field within themselves – they have high **permeability μ** .

Many lines of force will take a "shortcut" through a piece of iron around a magnet.

All other materials are "non magnetizable".

They have $\mu = \mu_0 = 4\pi \cdot 10^{-7}$

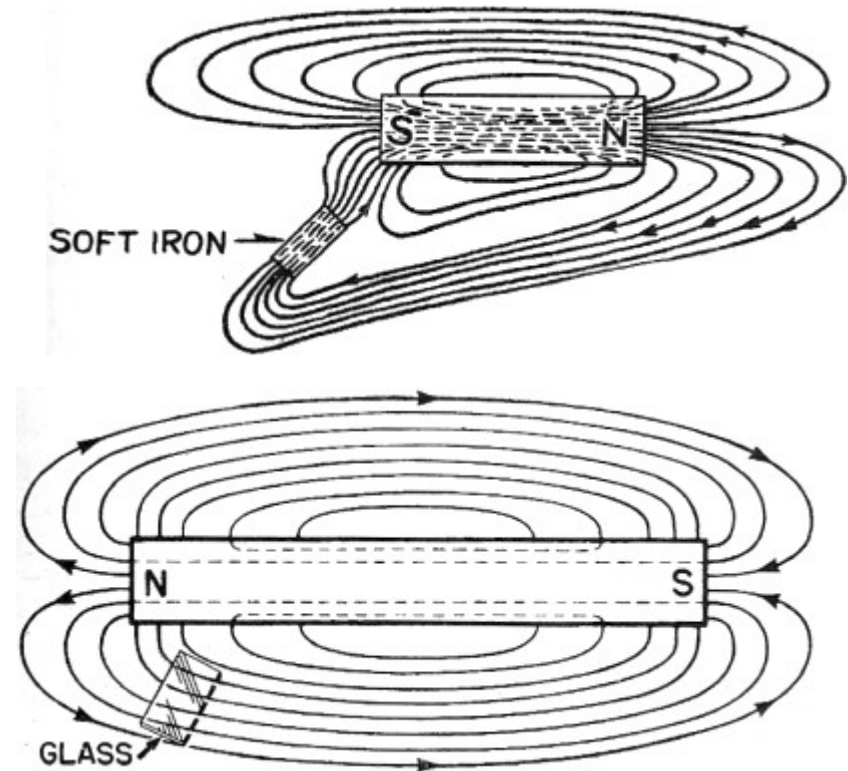

Relative Permeability μ_r

It is convenient to compare different materials permeability with vacuums. The relative permeability is called μ_r .

$$\boxed{\mu = \mu_r \cdot \mu_0} \quad \mu_0 = 4\pi \cdot 10^{-7}$$

Permalloy $\mu_r \approx 8000$. Mu-metal $\mu_r \approx 20000$.

These are expensive materials that can be used as "shields" against magnetic fields.

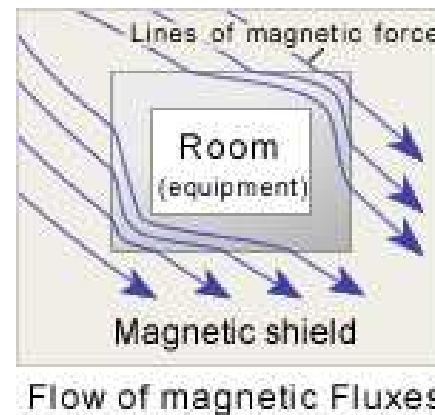

Quick question? Permeability

(Ex. 9.6) Two magnets are positioned on each side of a metal. The metal has $\mu_r = 1$. Draw the magnetic force lines in the figure. Mark with arrows field direction.



Quick question! Permeability

The magnetic field is not affected by the metal piece, it has relative permeability 1, the same as the air!

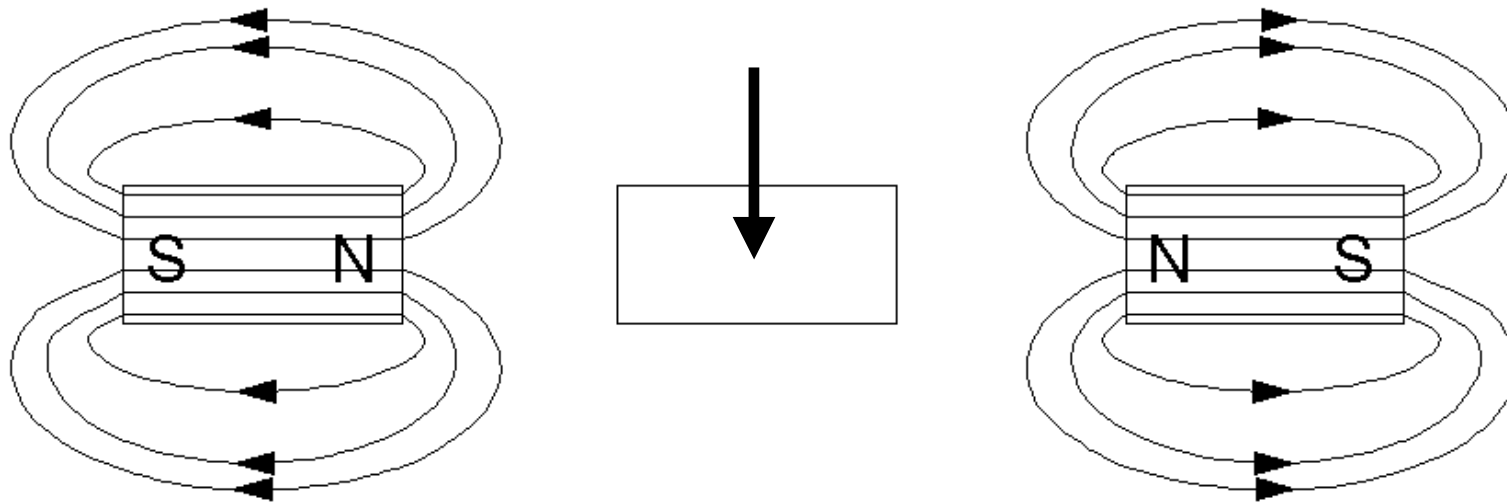

William Sandqvist william@kth.se

Both our earth and the electron are magnets

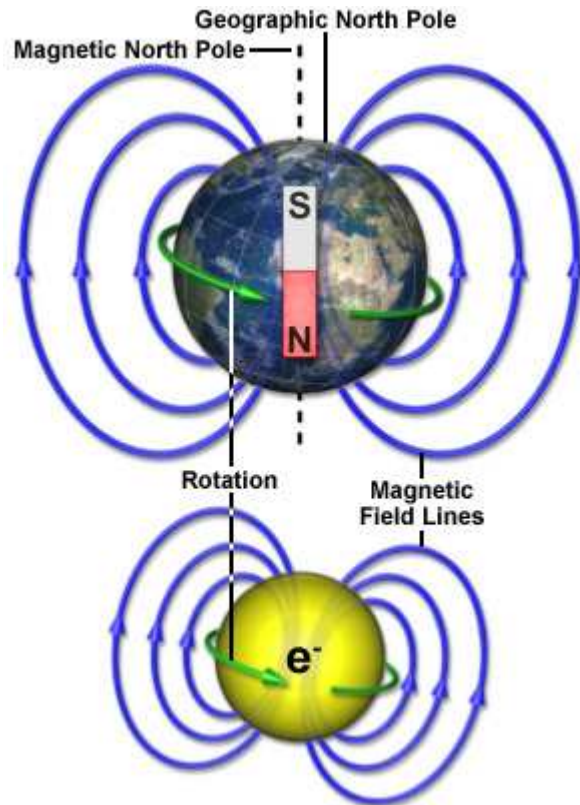

The Earth and electrons are both magnets.

- The earth *rotating* ironcore creates a magnetic field



- The electron *spin* creates a magnetic field



Right hand rule

- The electric current creates a magnetic field.

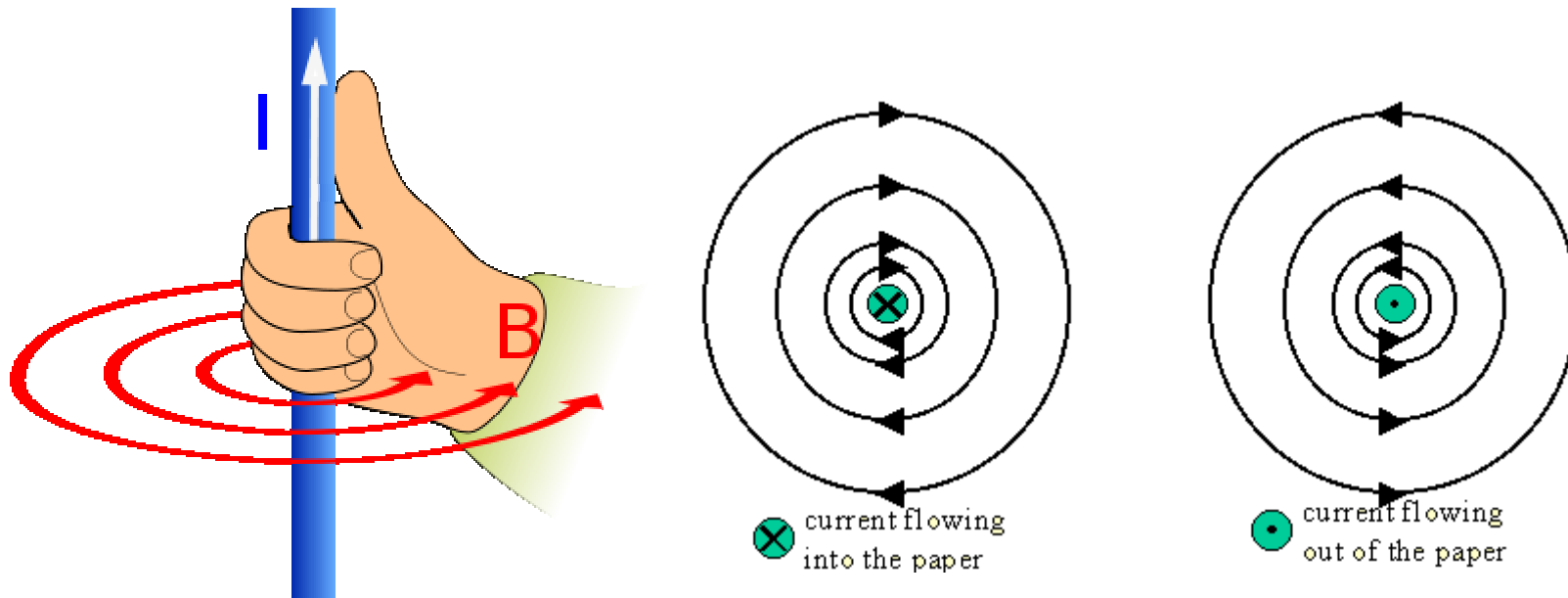

?

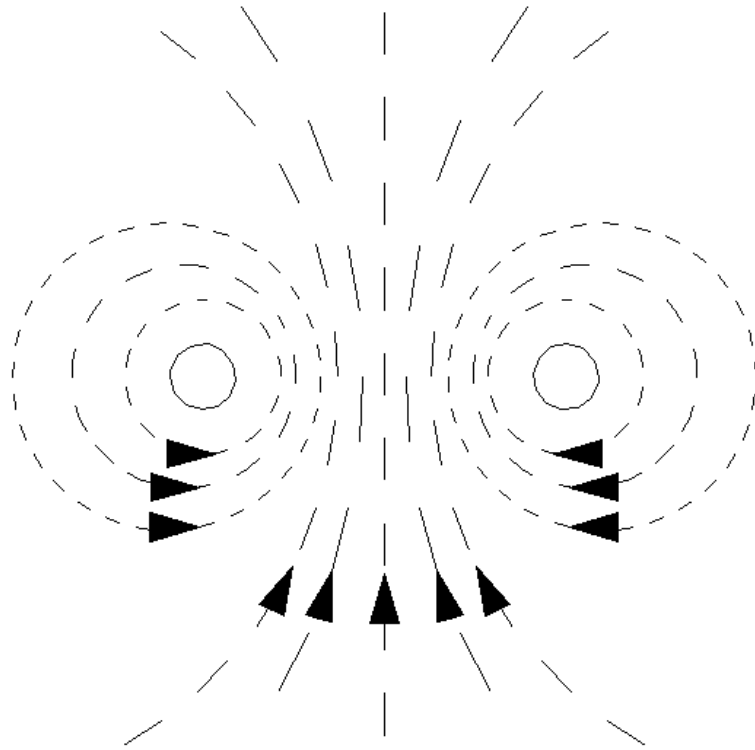

William Sandqvist william@kth.se



(Ex. 9.8)

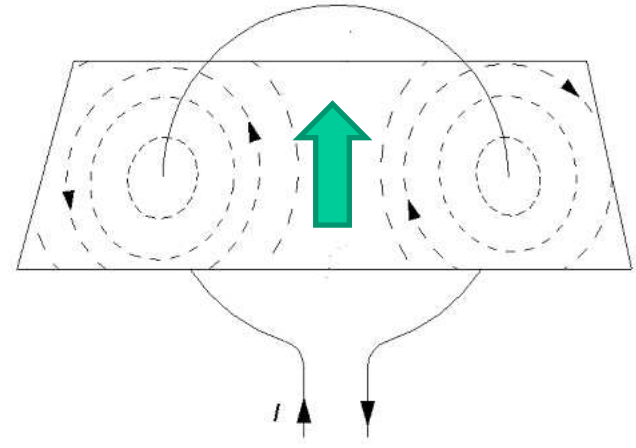

!

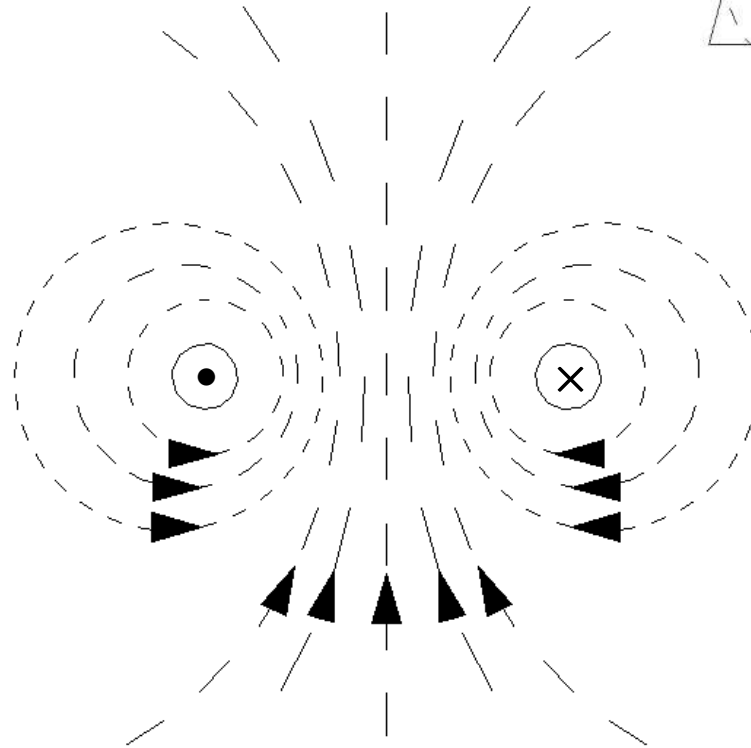

There will be interacting field inside a loop!



Electromagnet

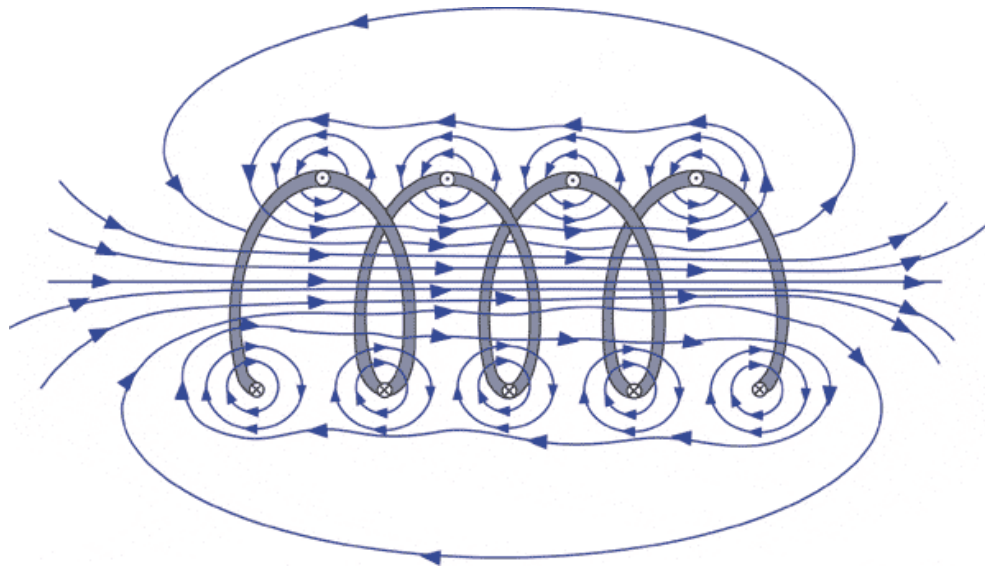

Electromagnet

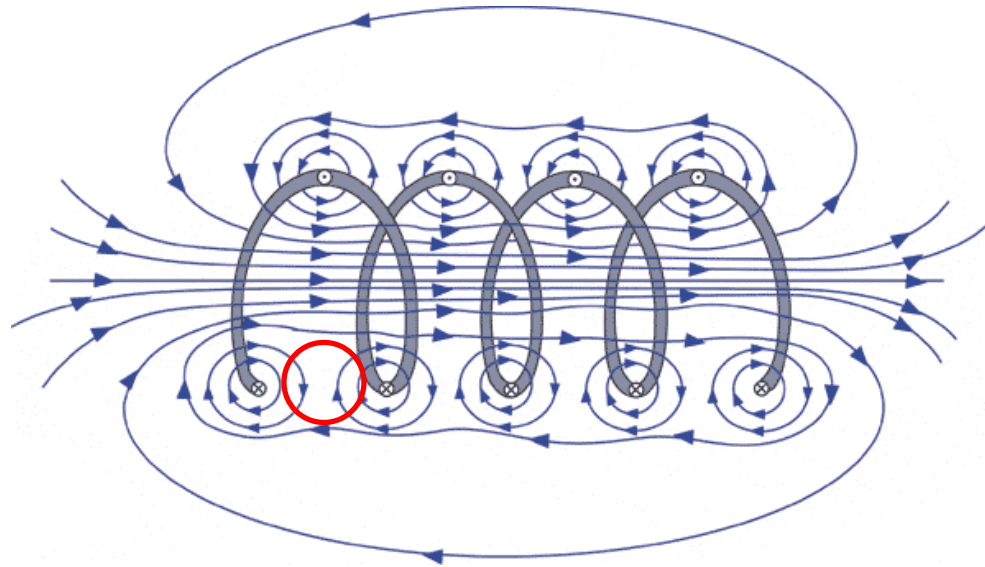

Between the loops **counteracts** the field lines each other

Electromagnet

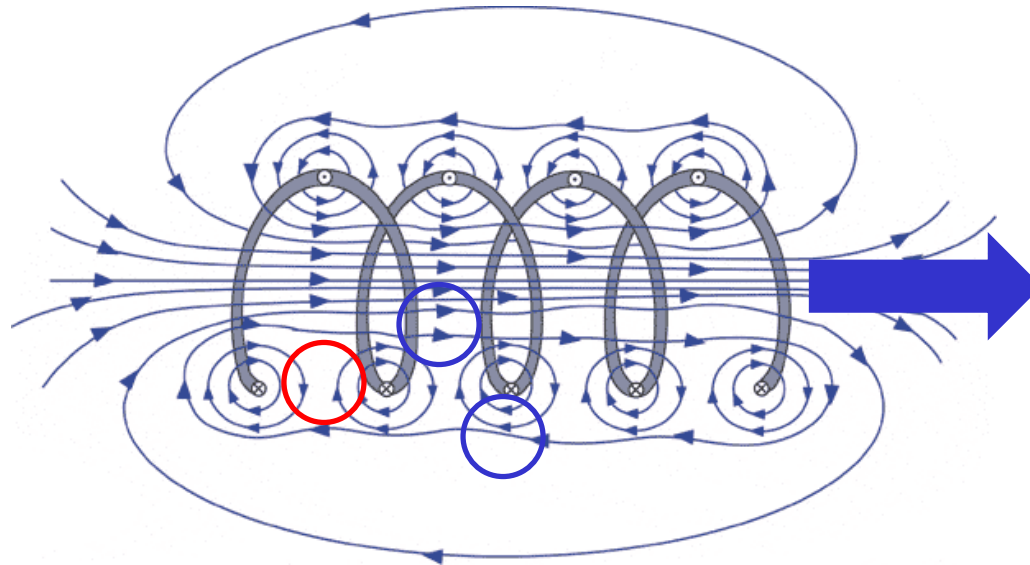

Between the loops **counteracts** the field lines each other

Inside the loops the field lines **amplify** each other.

Field image becomes as for a bar magnet

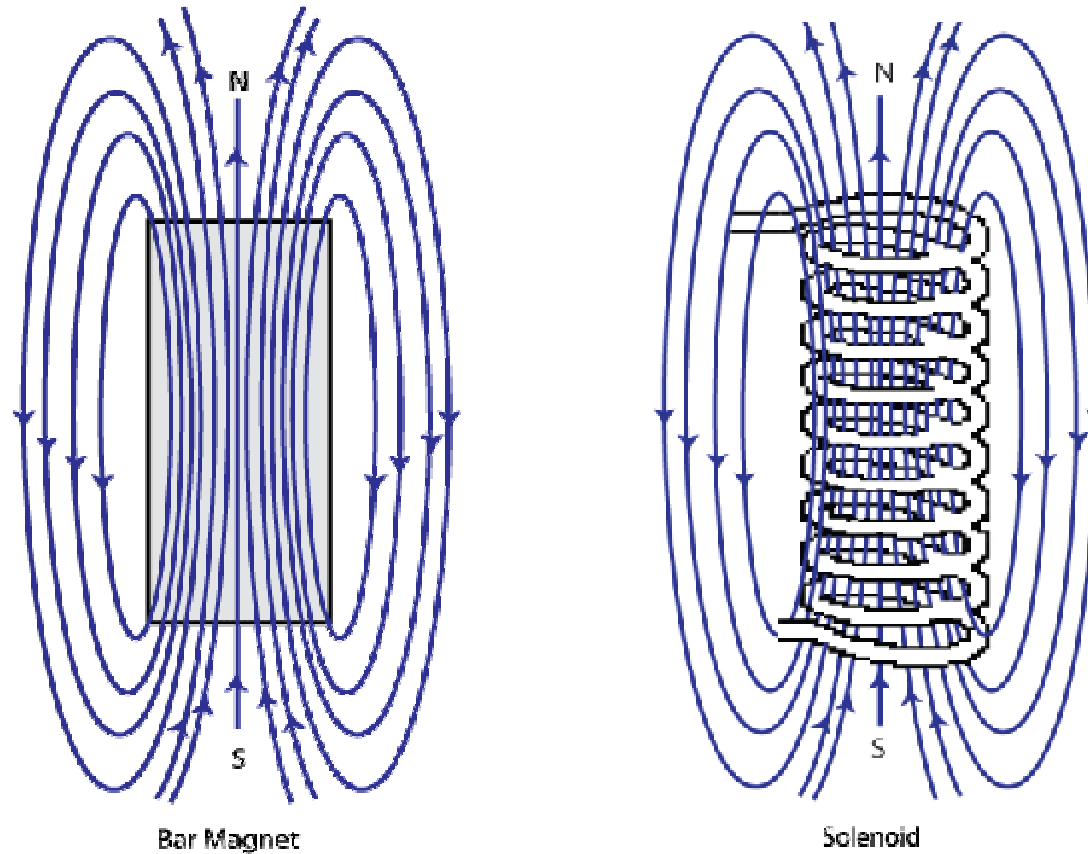

William Sandqvist william@kth.se

Motor principle

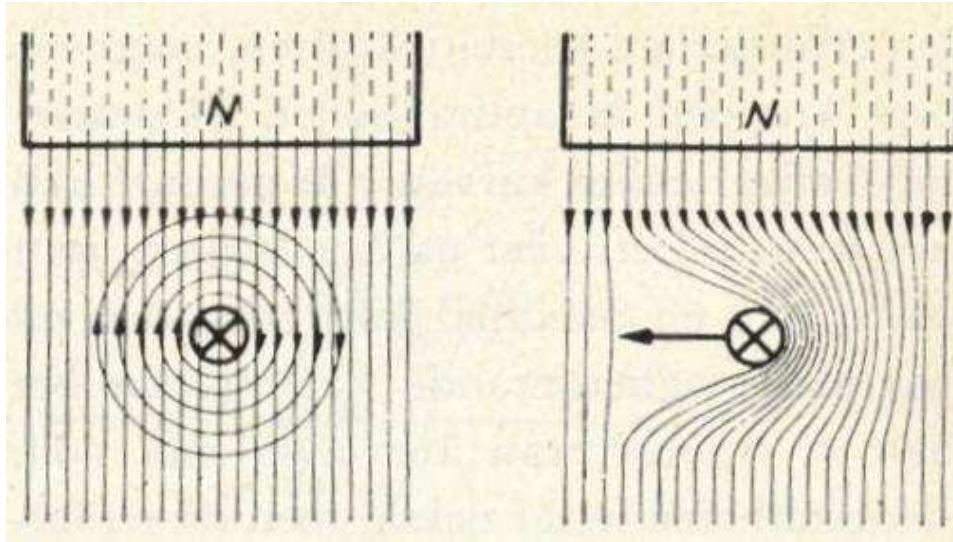

Force acts in electric motors based on this principle.

A current carrying conductor is located in a magnetic field B (the length l is the portion of conductor that is in the field). The magnetic force lines can not intersect. The field is therefore enhanced on one side of the conductor and weakened on the other. A force F acts to eject the leader out of the field.

$$F = B \cdot I \cdot l$$

DC-motor

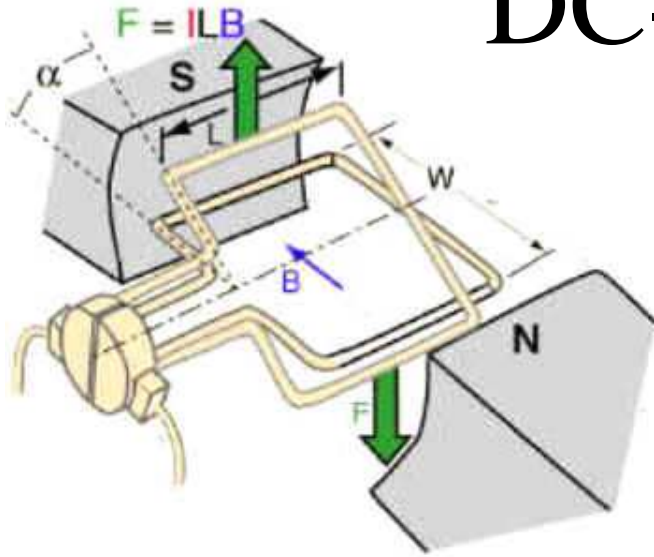

$$F = B \cdot I \cdot l$$

The permanent magnet DC motor utilizes the relationship
 $F = B \cdot I \cdot l$

When the loop is twisted half a turn the force action would stop if not a switching device changes the current direction.

Generator principle

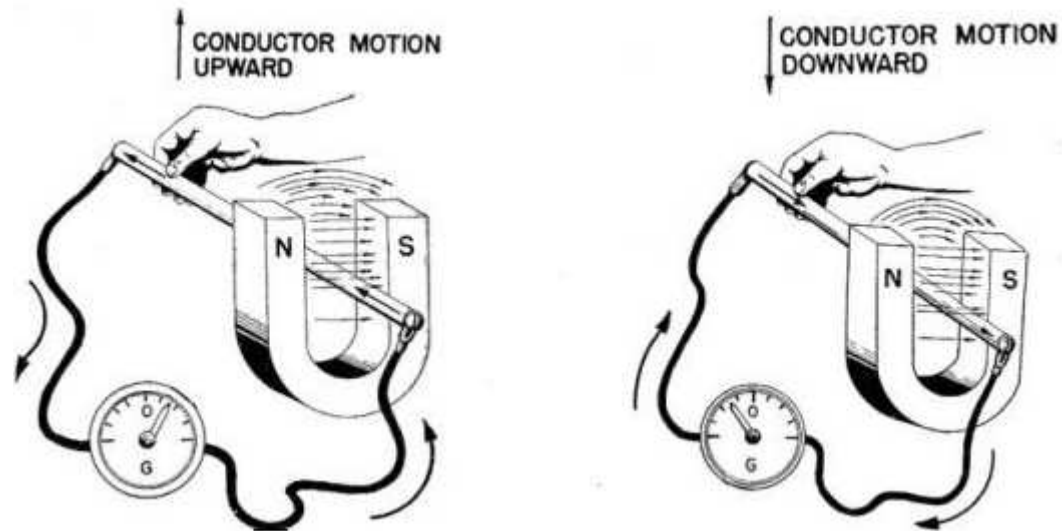
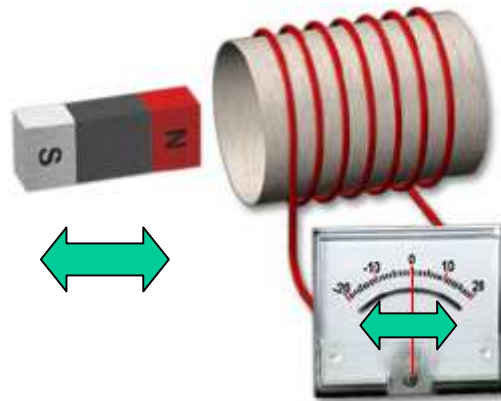

Figure: Electricity - Basic Navy Training Courses
U.S. GOVERNMENT PRINTING OFFICE 1945

Conversely, a voltage/current is induced in a conductor moving in a magnetic field.

Induction Law, amount (Faraday)



$$e = N \frac{d\Phi}{dt}$$

The induced emf amount is proportional to **flux speed of change**. Faraday induction law. When applied to a coil instead of a single conductor the emf also becomes proportional to the number of windings N .

Lenz law

(Direction = counteracting)

Faraday's Law

$$Emf = -N \frac{\Delta\Phi}{\Delta t}$$

Lenz's Law

The diagram shows the equation $Emf = -N \frac{\Delta\Phi}{\Delta t}$. A callout box labeled "Faraday's Law" points to the entire equation. Another callout box labeled "Lenz's Law" points specifically to the negative sign in the equation.

Lenz law says that the induced voltage have a direction so the current will counteract the movement.

(If it were the other way around so it would be easy to build a perpetual motion machine!)

Quick question? Lenz law (9.9)

We will draw out the magnet (as a cork from a bottle) from the coil.
Which direction will the current I have?

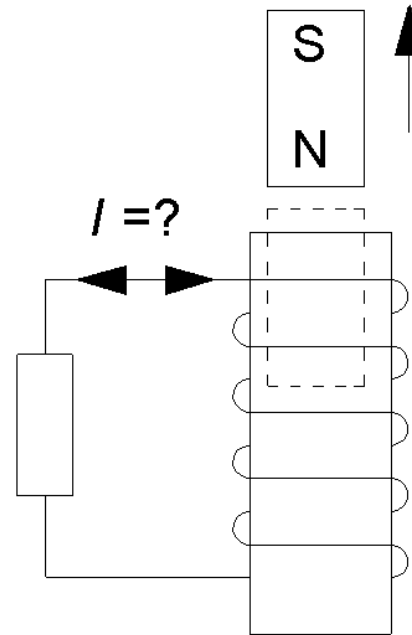

Quick question! Lenz law (9.9)

We will draw out the magnet (as a cork from a bottle) from the coil.
Which direction will the current I have?

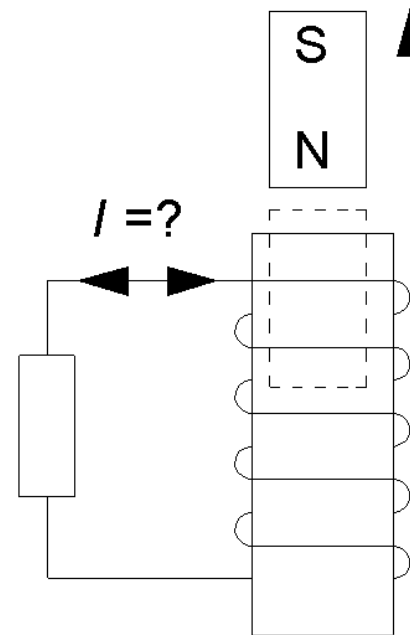
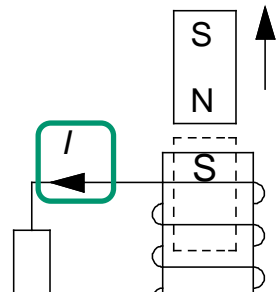

The current will counteract the movement. So will it be if the magnet leaves the coil at the "south side" (= attraction between the coil and magnet). Right hand rule then gives the current direction is out from the winding.



William Sandqvist william@kth.se

Inductance

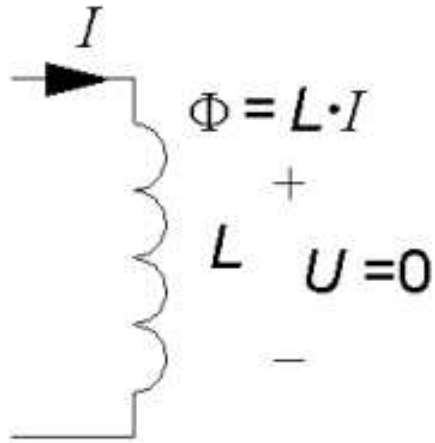

- A **constant current** I through a coil gives rise to a magnetic flow Φ . The flux is proportional to the current I , but also depends on the coil's *geometric design*.

$$\boxed{\Phi = L \cdot I}$$

The proportionality constant L is the coil inductance with the unit Henry [H].

If the current is unchanging, constant, there will be no voltage drop across the coil $U = 0$.

Self-induction

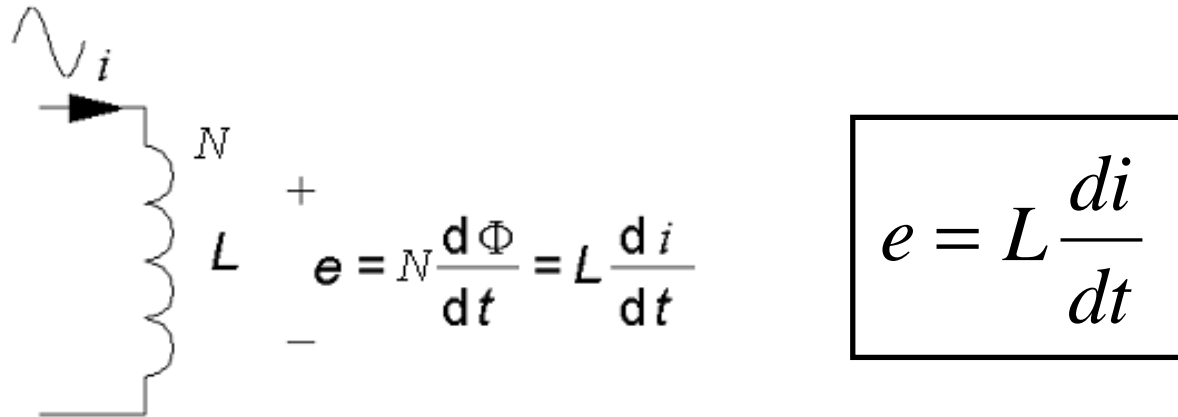

- A changing current I is giving rise to a changing flux, and then a counteracting voltage e across the coil is induced. This is the self-induction. The coil may be a voltage drop caused by the current rate of change.

Lenz law counteracting here means that we are defining the direction of the voltage drop as for a resistor.

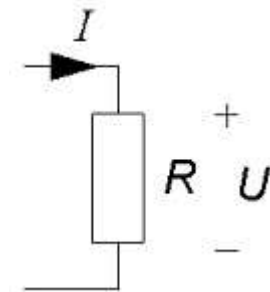

William Sandqvist william@kth.se

Inductance calculation

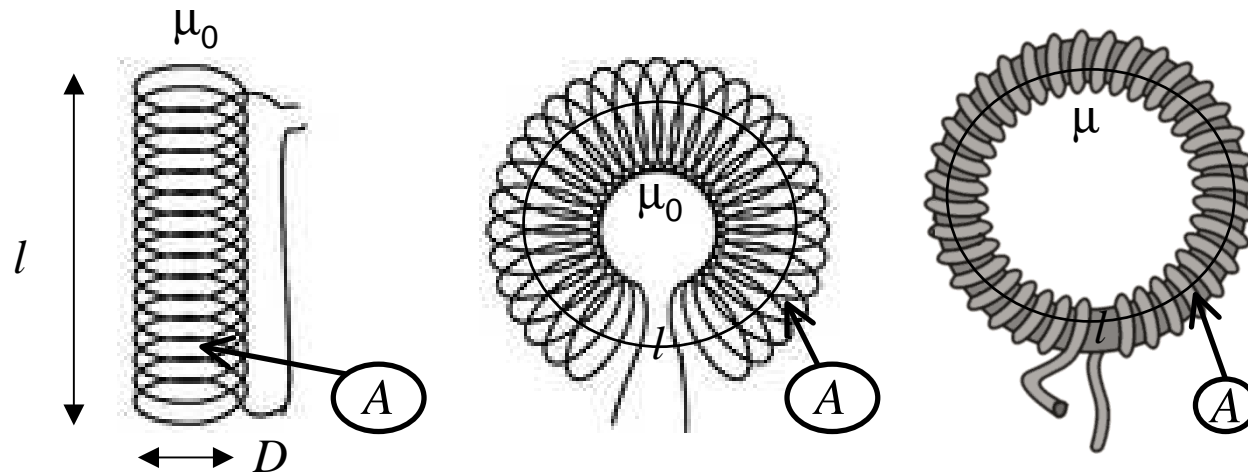

For coils that have constant flux density over the entire cross-sectional area, there is a simple formula for calculating the inductance. This applies toroidal coil and "elongated coil" ($l/D \gg 10$).

$$L = \frac{N^2 \cdot \mu \cdot A}{l} = \frac{N^2 \cdot \mu_r \mu_0 \cdot A}{l}$$

Why do you think the factor N^2 is included in all inductance calculation formulas?

(9.11) Quick Question? $L \propto N^2$

$$L = \frac{N^2 \cdot \mu \cdot A}{l}$$

Suppose that a coil is wound with $N = 100$ turns and then have the inductance 1 H. How many turns will be unwound if you want to change the coil so that the inductance becomes $\frac{1}{2}$ H?



(9.11) Quick Question! $L \propto N^2$

$$L = \frac{N^2 \cdot \mu \cdot A}{l}$$

Suppose that a coil is wound with $N = 100$ turns and then have the inductance 1 H. How many turns will be unwound if you want to change the coil so that the inductance becomes $\frac{1}{2}$ H?

- $L = 1 = 100^2 \cdot K \Rightarrow K = 10^{-4}$
- $0,5 = N^2 \cdot 10^{-4} \Rightarrow N = \sqrt{5000} = 71$

Unwound 29 turns so the inductance is halved!
(100-29=71)



William Sandqvist william@kth.se

Inductor transients

Since the coil counteracts all current changes one may wonder what happens when you connect or disconnect, the coil to a circuit?

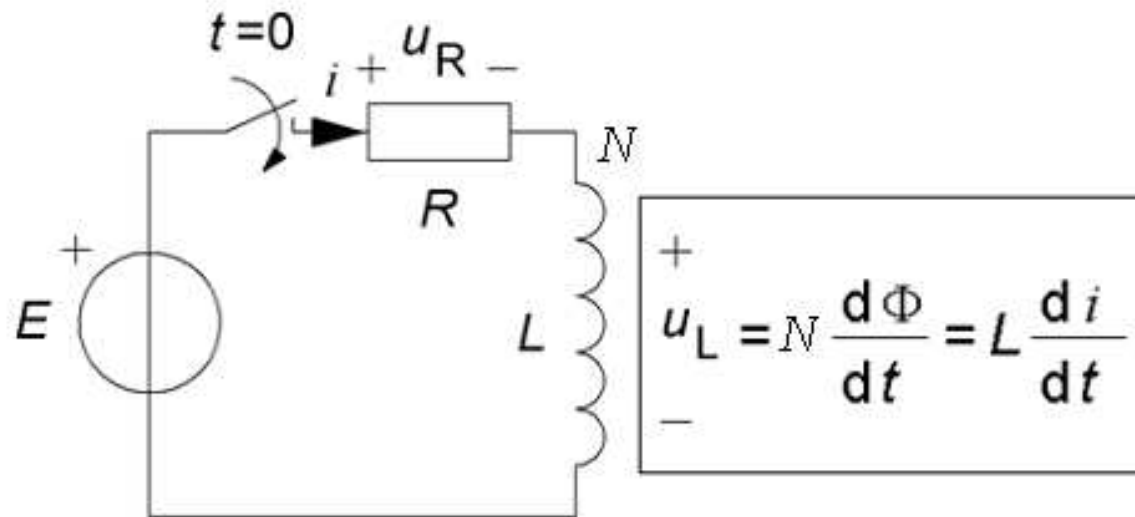

Inductor transients

What happens when a coil is connected to a battery?

We assume that the coil in addition to its inductance L , also has a resistance R from the wire the coil is wound with.

(If R is the internal resistance of the coil then we can not reach to measure u_R and u_L separately.)

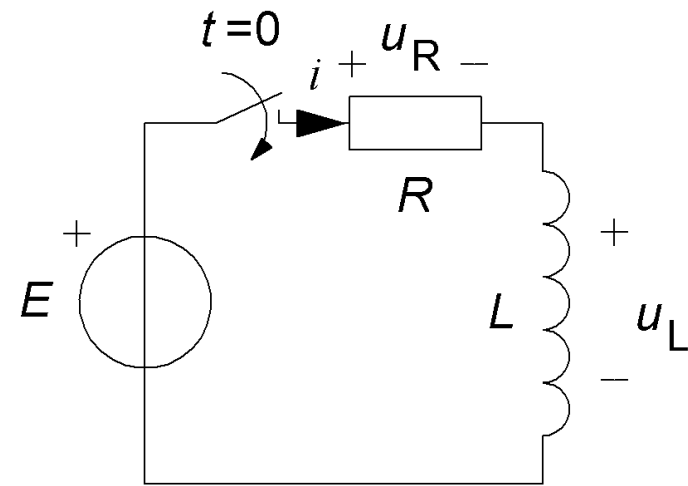

Inductor transients

What happens when a coil is connected to a battery?

We assume that the coil in addition to its inductance L , also has a resistance R from the wire the coil is wound with.

(If R is the internal resistance of the coil then we can not reach to measure u_R and u_L separately.)

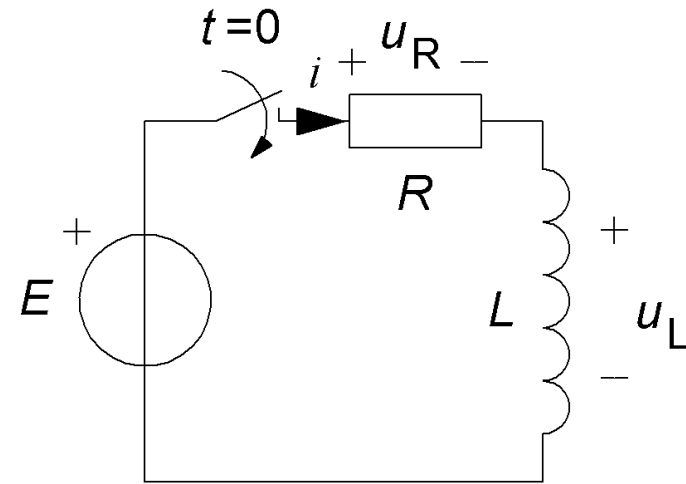

$$E = u_R + u_L \quad u_L = L \cdot \frac{di}{dt} \quad \Rightarrow \quad E = i \cdot R + L \cdot \frac{di}{dt}$$

Inductor transients

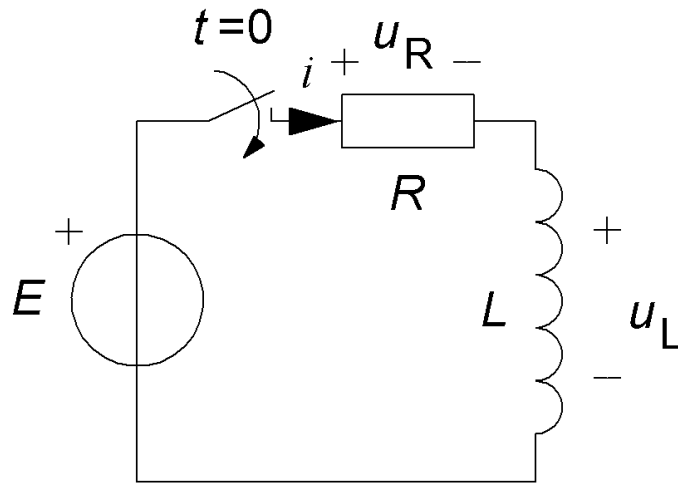

$$E = i \cdot R + L \cdot \frac{di}{dt}$$

- The solution to this differential equation is a **exponential-function** with a time constant.

$$i(t) = \frac{E}{R} \cdot \left(1 - e^{-\frac{t \cdot R}{L}} \right)$$

The inductor time constant

$$i(t) = \frac{E}{R} \cdot \left(1 - e^{-\frac{tR}{L}} \right)$$

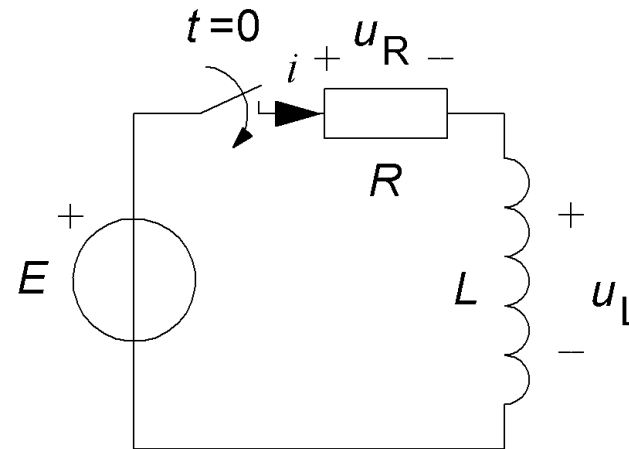

L/R is called the time constant and is usually denoted by τ .

$$\tau = \frac{L}{R}$$

William Sandqvist william@kth.se

Energy stored in magnetic field

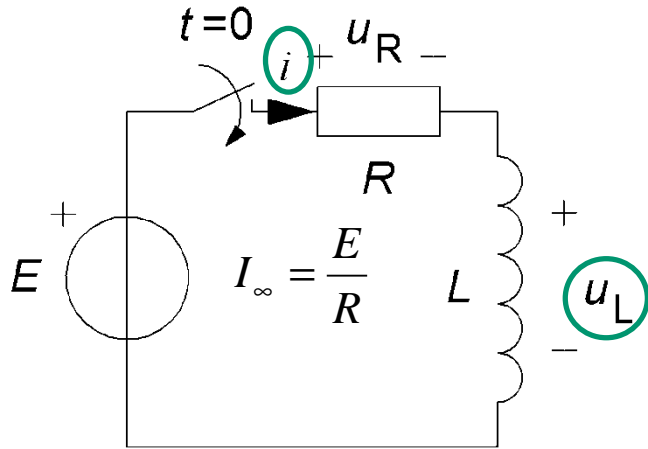

$$u_L = L \cdot \frac{di}{dt}$$

Instantaneous power:

$$p = i \cdot u_L = i \cdot L \cdot \frac{di}{dt}$$

Energy:

$$W = \int_{t=0}^{t=\infty} p \, dt = \int_{t=0}^{t=\infty} L \cdot i \cdot \frac{di}{dt} \, dt = \int_{i=0}^{i=I_\infty} L \cdot i \, di = \frac{1}{2} \cdot L \cdot I_\infty^2$$

Stored energy in the magnetic field:

$$W_m = \frac{1}{2} \cdot L \cdot I^2$$

Remember the formula, but its allowed to skip the derivation...

Energy in capacitor and inductor

$$W_L = \frac{1}{2} L \cdot I^2 \quad W_E = \frac{1}{2} C \cdot U^2$$

- **Imagined electromagnetic motor:**

$W_M = L \cdot I^2 / 2$ copper "tolerate" 3A/mm²
inductance 1 H is a reasonable value for a motor.

- **Imagined electrostatic motor:**

$W_E = C \cdot U^2 / 2$ air "tolerates" 2,5 kV/mm
capacitance 100 pF is a reasonable value for a motor. 1 mm between moving parts is reasonable.



*Now all electrostatic motors
are micromechanical ...
According to the calculations
this fact will probably
persist!*

$$W_M \approx \frac{1 \cdot 3^2}{2} = 4,5 \text{ J} \quad W_E \approx \frac{100 \cdot 10^{-12} \cdot (2,5 \cdot 10^3)^2}{2} = 3,13 \cdot 10^{-4} \text{ J}$$

Inductors

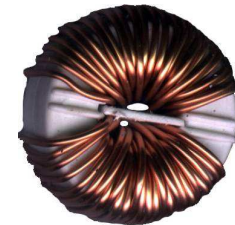

Continuity requirements

Summary

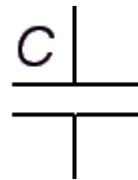

The Capacitor has voltage inertia

In a capacitor, charging is always continuous
The capacitor **voltage is always continuous.**

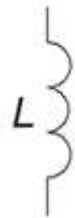

The Inductor has current inertia

In an inductor the magnetic flux is always continuous
In an inductor **current is always continuous.**

William Sandqvist william@kth.se