

Master Thesis Work in CFD with Fluid Structure Interaction

Flow induced vibrations (FIV) is an important phenomena in the design of fluid conveying systems and components subjected to external or internal fluid flow. As the structure response to the fluid forcing grows in amplitude the motion of the structure itself changes the flow pattern and the resulting loads significantly and a fluid structure interaction (FSI) is created. In order to assess FSI phenomenon computational fluid mechanics is an important tool. Due to the strong coupling, simultaneous calculation of both the transient fluid flow and the structural response is necessary. Recent development of computational software for coupled fluid/structure analyses has made it possible to address transient flows and complex geometry for industrial applications.

The input data to the CFD/FSI analysis to be carried out in this master thesis are experimental tests, which have been performed for the in-core neutron flux detector housing tubes. These tubes are located in between the fuel bundles and hold the neutron flux detectors.

The experimental geometry is simplified and scaled down to a more suitable size. The experimental data consists of time history data of the tube displacement/velocity and pressures at different locations in the narrow channel between the tube and the walls of the surrounding fuel bundles for varying flow velocities.

The CAD geometry used for the CFD analysis is shown below.

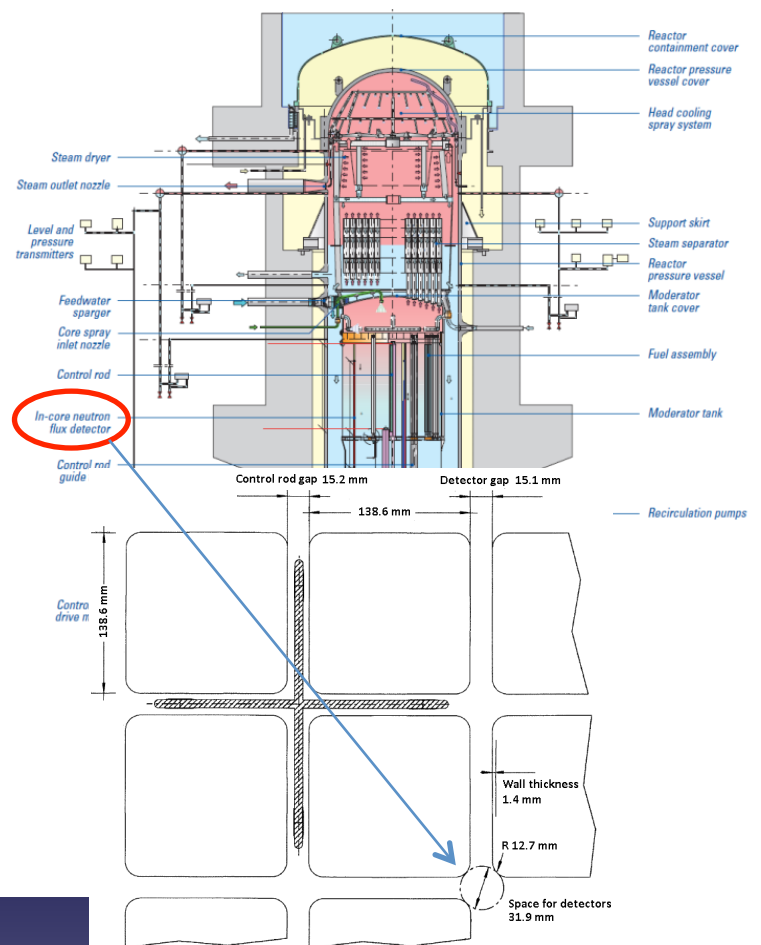
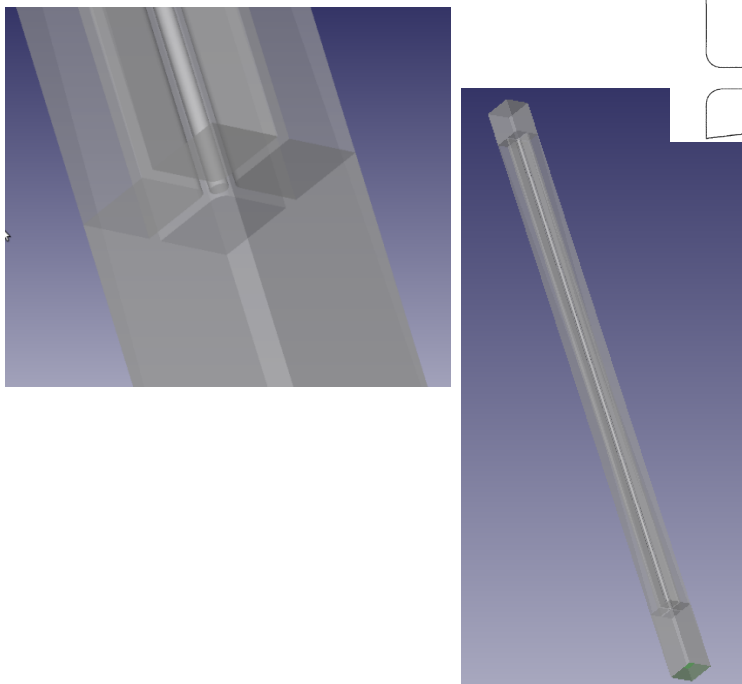

The high performance computing system to be used during this master thesis is BESKOW system at PDC High Performance Computing center at KTH.

According to the preliminary planing the following tasks can be carried out:

- a) CFD/FSI analysis
- b) Refinement of the geometry
- c) Scalability measurement of the model
- d) Otimization and load balancing of the model

The work will be done using OpenFOAM open source software.

For more information please contact:

Eric Lillberg 070-5372994 eric.lillberg@vattenfall.com

Lilit Axner 0722 503 899 lilit@kth.se