

Laboratory VHDL introduction

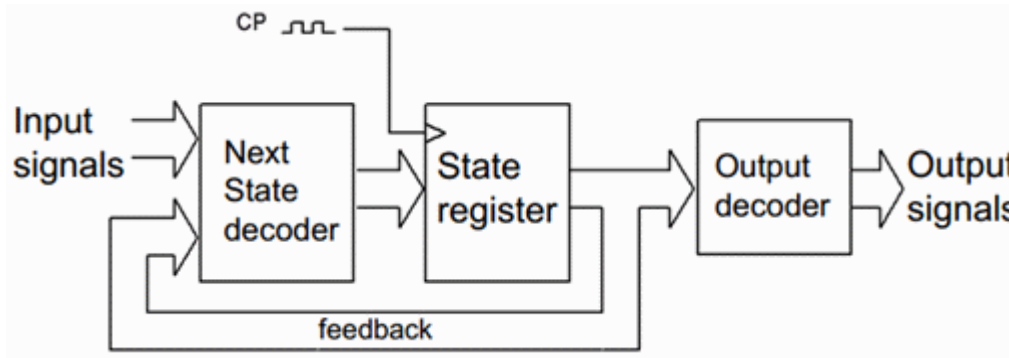

Digital Design IE1204 (Note! *not* included for IE1205)



Attention! To access the laboratory experiment you must have:

- booked a lab time in the reservation system (Daisy).
- completed your personal knowledge control on the Web (Web-quiz).
- done all preparation tasks mentioned in the lab booklet.

During the lab you work in groups of two, but both students are responsible individually for their preparation and implementation.

Both students should bring their lab booklets. This frontpage is used as your **receipt** that the lab is completed. Save the receipt until you have received the full course registered in the database (Ladok).

*Since this is your receipt you **must** fill in the table with ink.*

Name:			
Social Security Number:			
• Knowledge Control (Web-quiz)			
Bundle no:		Date:	
Lab-assistant receipt:			
• Preparation tasks in the lab booklet			
Lab-assistant receipt:			
• Lab implementation			
Laboration date:			
Lab-assistant receipt:			

Introduction

This lab is about how to design digital logic with VHDL language and modern CAD software. The idea is that you'll get a glimpse of how a "Digital" engineer work. VHDL language is a very complex programming language, and it is not reasonable to "learn" that this brief first Digital Design Course.

When you solve the lab assignments, you have therefore been given tutorials and template code on the course web.

The school has several good VHDL courses that can be chosen by those who want to know more, and who want to work with Digital Design in the future.

The best way to get to know a program is to install it on your own computer. Then you can in peace search through menus and help pages, and can take the time it takes to sort out what you might have misunderstood.

If "computer hassles" threaten to consume too much time for you, you can also find the programs installed in the school's Windows computer rooms - as a backup solution.

The goal of the lab

- Become familiar with modern CAD software, Quartus and ModelSim.
- Show how to simulate a digital design (a Moore-machine), how to generate input signals, stimuli, and how to observe the outputs and behavior (ModelSim-Wave).
- Orienting yourself on how a digital technician can write a VHDL "test bench" to ensure that the construction is completely correct.
- Practice the VHDL-construction of a state machine from a given state diagram (revise and expand a given template program).
- Practice how to tie together the design "signals" with target chip "pins".
- Show how you program the target chip (MAX3000), and trying the operation in reality.

Attention! Your lab time may be prior all course elements that may be needed for the lab has been lectured. You would then have to read the course material for yourself in advance - there are links to all slides for the lectures and exercises.

Attention! Lab equipment is completed. No wires should be changed, not added or removed.

A VHDL-code lock

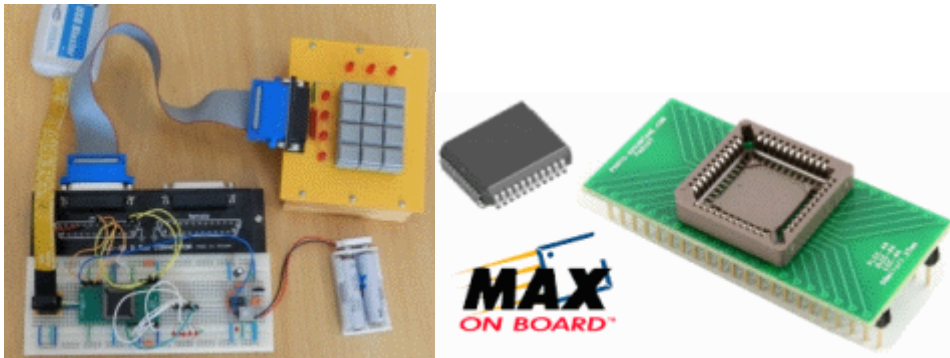

Lab task is to construct a code lock that opens to a unique four-digit code, but we begin by studying a simpler template program, a code lock that opens to one key!

- **Preparation task 1 (done before the lab at home)**

Install the programs **Quartus II** and **ModelSim** on your own computer.

Follow the steps in the tutorial on the course web - [Install the programs on your computer.](#)

- **Laboratory task 1 (do at lab in school)**

Log on to the lab computer. On the school centrally managed lab computers You do not have rights to install software. **Quartus II** and **ModelSim** are already installed. You may not access the folders under `C:\`. At the laboratory, you should therefore use your "server" folder `H:\`.

- Create a folder `H:\MAXWork\` for the files in this lab.
- Important operating system setup. Show file extensions should be set at all programming courses!
[Windows 7 show fileextensions](#)

- **Preparation task 2 (done before the lab at home)**

Start Quartus and create a project `codeLock`. Bring the content of the file [lockmall.vhd](#) as the project VHDL-file and then compile the code.

Follow the steps in the tutorial on the course web - [VHDL-program with Quartus.](#)

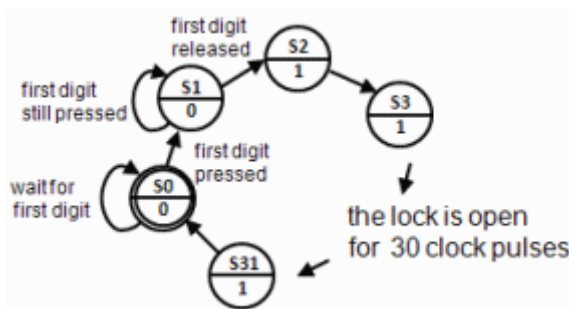

Read about the template program VHDL code in the description on the course web

- [VHDL for a code lock](#).

Read on how to tie the signal names to specific pins of the target chip in Quartus.

- [Pin-planning in Quartus](#).

Read about how to use the Quartus programming function with a JTAG USB Blaster.

- [Chip-programing with Quartus](#).

- **Laboratory task 2 (do at lab in school)**

- Start Quartus and create a project `code lock` in your server-folder `H:\MAXWork\`. Use the content of the file [lockmall.vhd](#) as the project VHDL-file and then compile the code.
- Lab equipments have different wiring! Examine your lab equipment and enter the Pin-planning table, and thereafter **Pin Planner** in Quartus.

Follow the steps in the tutorial on the course web - [Pin-planning in Quartus](#)

Node Name	Direction	Location
clk	Input	PIN_
K[1..3]	Input	
K[1]	Input	PIN_
K[2]	Input	PIN_
K[3]	Input	PIN_
q[4..0]	Output	
q[4]	Output	PIN_
q[3]	Output	PIN_
q[2]	Output	PIN_
q[1]	Output	PIN_
q[0]	Output	PIN_
R[1..4]	Input	
R[1]	Input	PIN_
R[2]	Input	PIN_
R[3]	Input	PIN_
R[4]	Input	PIN_
UNLOCK	Output	PIN_

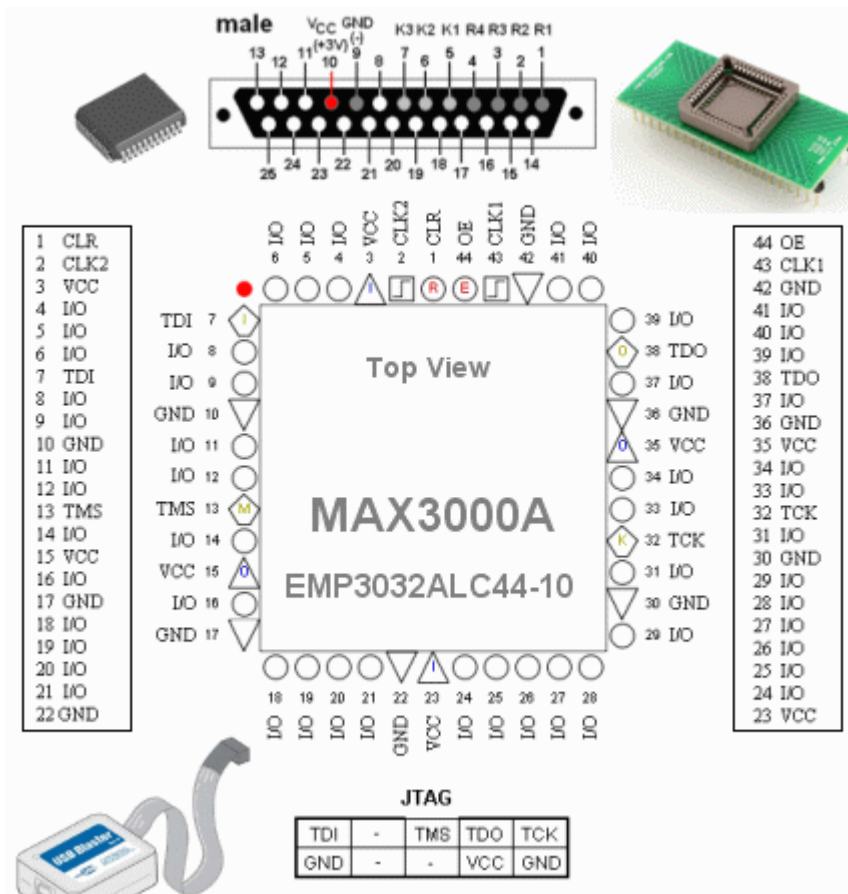

Description of the pin-symbols see figure.

- When you have completed the pin planner in Quartus so recompile the project.
- Program the device with the USB blaster.
- Check that the code lock opens when you press the "1" and then release the key.

Symbol	Pin Type
○	User I/O
●	User Assigned I/O
●	Filter Assigned I/O
○	Unbonded Pad
●	Reserved Pin
E	DEV_OE
R	DEV_CLR
⌋	CLK
I	TDI
K	TCK
M	TMS
O	TDO
△	VCCINT
△	VCCIO
▽	GND

• Preparation task 3 (done before the lab at home)

At home, you have no hardware, no laboratory equipment. In such situations one usually simulate the code to see if it is correct.

The leading simulation software **ModelSim** is available in a version for Altera's chips. Start ModelSim and simulate the VHDL-code with the content from lockmall.vhd as VHDL-file.

Follow the steps in the tutorial on the course web - [Simulate with ModelSim](#).

 [lockmall.vhd](#) ( [lockmall.txt](#))

- **Laboratory task 3 (do at lab in school)**

Even when having access to the hardware, it is common to mix simulations with hardware test.

Carry out the same simulation in school that you practiced at home, ie show in the **wave window** that the lock opens for "1". Show Your lab assistant your "simulation expertise."

- **Preparation task 3 (done before the lab at home)**

Design of Digital hardware can often result in the production of an ASIC - An application specific Integrated Circuit. It is then often several months of lead time and, manufacturing costs of the order of several million dollars.

Then you have to be sure that the design is absolutely correct!

(At the lab, we have a better starting point than the ASIC designer. If your design on a programmable CPLD chip is wrong, You get the chance to reprogram it - again and again.)

As you can see, it is the test engineer who is Digital Technology Hero!

VHDL-language has various tools to enhance the ability to be able to write correct code.

- To reduce the risk of errors when transferring information from the data sheets, you can use index that runs up or down, to suit the method that was used in the data sheet.
- You has also the ability to create user-defined data types that fit the description of the construction. One can therefore often write VHDL code that is "obviously" correct!
- One can write a VHDL test bench. This is simulation code that can be used to test many/all signal combinations that the circuit may be exposed to.

Attention! A test bench is usually a more complicated program than the original design as it relates to test!

These lines from the template program is an example of code that *obviously* follow the given state diagram.

```
case state is
  when 0 => if (K = "001" and R = "0001")      then nextstate <= 1;
            else nextstate <= 0;
            end if;
  when 1 => if (K = "001" and R = "0001")      then nextstate <= 1;
            elsif (K = "000" and R = "0000") then nextstate <= 2;
            else nextstate <= 0;
            end if;
            . . .
```

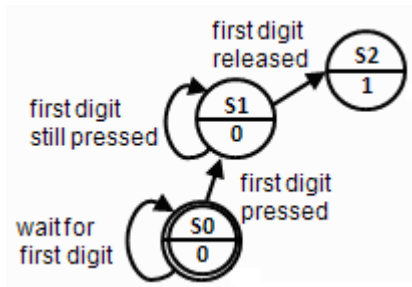

However, if one takes over the code from someone else, even if that person *promise* that it works, the situation is different.

```







case state is
  when 0 => if(((R(2)='0') and (R(3)='0') and (K(2)='0') and
(K(3)='1')) and
              ( not (( not ((K(1)='0') and (R(1)='0') and (R(4)='1'))))
and
              ( not ((K(1)='1') and (R(1)='1') and (R(4)='0'))))))
    then nextstate <= 1;
    else nextstate <= 0;
    end if;
  . . .

```

Here are the conditions written in such a way that it is no longer obvious what the code does - And therefore we do not know if it is correct or if, despite all the promises, it is incorrect?

Try now the code correctness with a (pre-written) test bench

Follow the steps in the tutorial on the course web - [Testbench in ModelSim](#).

-  [lockmall.vhd](#) ( [lockmall.txt](#))
-  [lockmall_with_error.vhd](#) ( [lockmall_with_error.txt](#))
-  [tb_lockmall.vhd](#) ( [tb_lockmall.txt](#))

• **Laboratory task 4 (do at lab in school)**

- Perform also the simulation of the test bench in the school, and show lab assistant your skills by simulating code with a test bench.
- Can you reveal anything wrong with the code? Show lab assistant.
- Close **ModelSim** and change to the program **Quartus II**. There you change the contents of the VHDL file from `lockmall.vhd` to `lockmall_with_error.vhd`. Compile and download the code to the MAX-chip.
- Check if the suspicious behavior from the simulation means that in practice You can open the code lock incorrectly?

- **Preparation task 5 (done before the lab at home)**

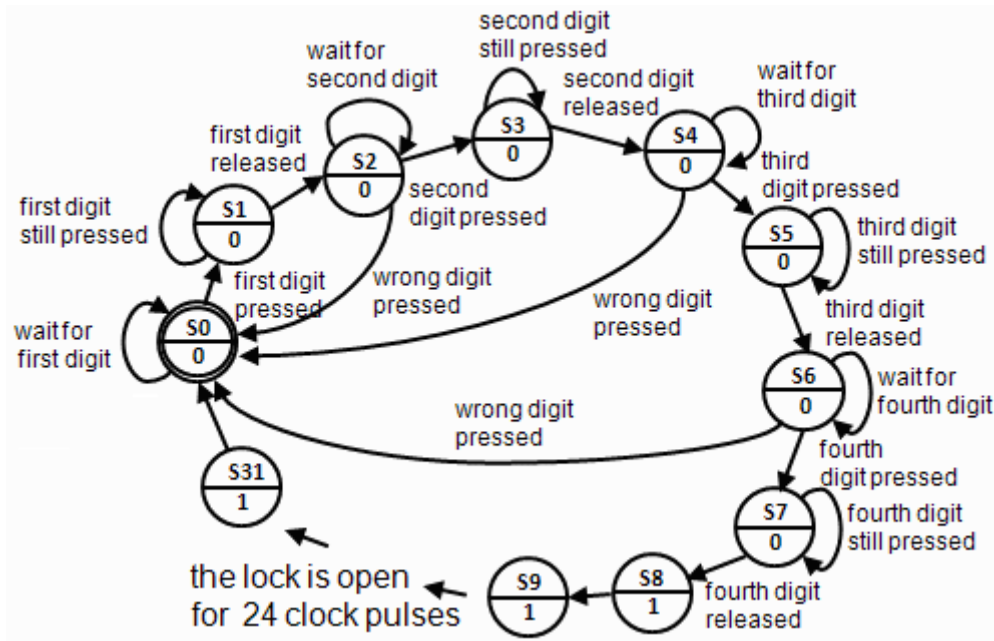

A code lock that opens to a single key press is of course ridiculously easy to force, normally you have a four digit code. Your task will be to develop the template program (lockmall.vhd) to such a lock with four digits - the last four digits of your civic number.

Prepare such a VHDL program at home. Check that it is possible to compile. Take with you the code to the school in any way, such as:

- Mail the text to yourself.
- Bring a USB flash drive with the code as a text file.
- Transfer the code to your server folder H:\.

Are you able to simulate the code at home, you'll increase the likelihood that you have the correct code from the start at school.

The time at the lab school will *not* be enough to write the program code from "scratch"!

- **Laboratory task 5 (do at lab in school)**

Make a code lock that opens to a four-digit code. Lab Assistant determines the digit combination so that - Two of the numbers taken from your preparation program, and the other two from your lab colleague preparation program.

- Show the working code lock for lab assistant.

Do you have time for more?

If you are well prepared for the lab, and if you are not suffering from intermittent connections or dead batteries, then you probably now have time for a "voluntary" task.

- Can you change the program so that it *also opens* for the previous *hidden* key combination?
(so that there is a "hardware trojan" within the chip)

Good Luck!

When you are finished clean the lab desk.

Bill of materials

The "bill of material" for the lab equipment, could be helpful if you ever would need to use simple MAX-chips yourself.

Altera USB-blaster ELFA 73-898-90
ALTERA CPLD EPM3032ALC44-10
Proto Advantage [PLCC-44 Socket to DIP-44 Adapter](#)
Breadboard MB-85 ELFA 48-428-37
Contact breadboard to 25-pol D-sub ELFA 48-426-96
Pin contact (JTAG) ELFA 43-155-03
Lightdiode with series resistor 5V red ELFA 75-012-59
Lightdiode with series resistor 5V yellow ELFA 75-015-11
Electronic chip 555 ELFA 73-042-65
Trimming Potentiometer 500 kΩ with adjustment knob ELFA 64-635-25

William Sandqvist william@kth.se

VHDL for a code lock

Description of the code lock template

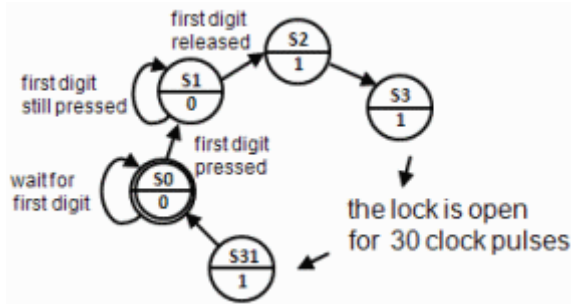

The Code Lock template applies to a simplified lock that opens when you press the key "1" and then release the key.

Almost all digital designs are now carried out using high-level languages like VHDL/Verilog. Our basic course in digital technology does not allow to teach VHDL language, however, you will be able to transform the "template code lock" into useful VHDL code at the lab.

If you think that the VHDL language seems interesting, then the school has several advanced digital technology courses

At lab you expand this code to create a four digit code lock!

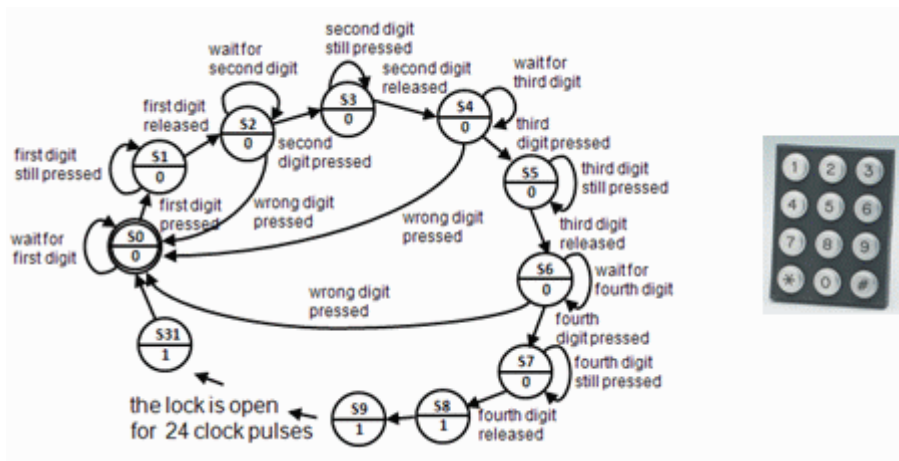

lockmall.vhd

```
library IEEE;
use IEEE.std_logic_1164.all;
use IEEE.std_logic_arith.all;

entity codelock is
  port( clk:      in  std_logic;
        K:      in  std_logic_vector(1 to 3);
        R:      in  std_logic_vector(1 to 4);
        q:      out std_logic_vector(4 downto 0);
        UNLOCK: out std_logic );
end codelock;

architecture behavior of codelock is
  subtype state_type is integer range 0 to 31;
  signal state, nextstate: state_type;

begin
  nextstate_decoder: -- next state decoding part
  process(state, K, R)
  begin
    case state is
      when 0 => if (K = "001" and R = "0001")      then nextstate <= 1;
                else nextstate <= 0;
                end if;
      when 1 => if (K = "001" and R = "0001")      then nextstate <= 1;
                elsif (K = "000" and R = "0000") then nextstate <= 2;
                else nextstate <= 0;
                end if;
      when 2 to 30 => nextstate <= state + 1;
      when 31 => nextstate <= 0;
    end case;
  end process;

  debug_output: -- display the state
  q <= conv_std_logic_vector(state,5);

  output_decoder: -- output decoder part
  process(state)
  begin
    case state is
      when 0 to 1  => UNLOCK <= '0';
      when 2 to 31 => UNLOCK <= '1';
    end case;
  end process;

  state_register: -- the state register part (the flipflops)
  process(clk)
  begin
    if rising_edge(clk) then
      state <= nextstate;
    end if;
  end process;
end behavior;
```

Moore machine

The code lock is The code lock is designed as a Moore machine.

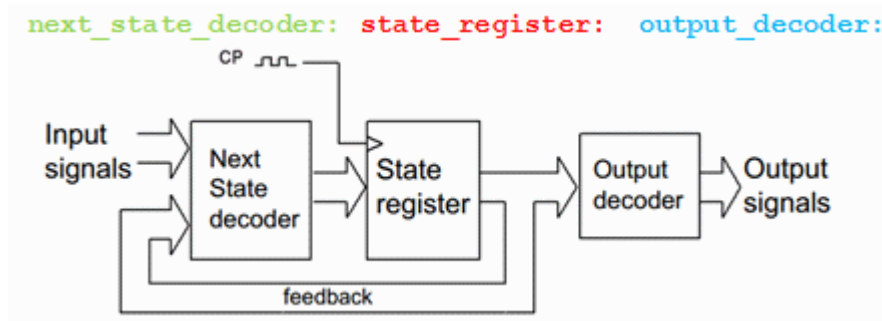

The different blocks in the code are identified with "labels".

```
next_state_decoder:  
output_decoder:  
state_register:
```

VHDL processes

With a "process" you can describe what should be performed in a block without having to go into the details of how this should be done.

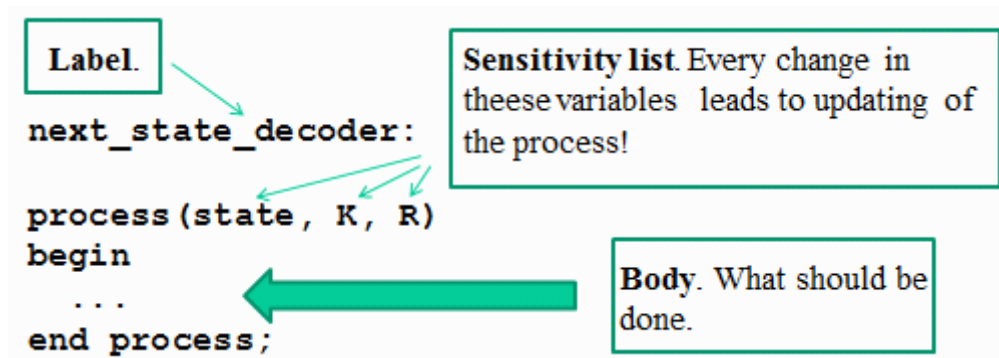

VHDL code is written as such processes.

Parts of the program

```

library IEEE;
use IEEE.std_logic_1164.all;
use IEEE.std_logic_arith.all;

start
entity codeLock is
  port( clk:      in  std_logic;
        K:      in  std_logic_vector(1 to 3);
        R:      in  std_logic_vector(1 to 4);
        q:      out std_logic_vector(4 downto 0);
        UNLOCK: out std_logic );
end codeLock;
end

start
architecture behavior of codeLock is
  subtype state_type is integer range 0 to 31;
  signal state, nextstate: state_type;

  begin
  nextstate_decoder: -- next state decoding part
  process(state, K, R)
  begin
    case state is
      when 0 => if (K = "100" and R = "0001") then nextstate <= 1;
                else nextstate <= 0;
                end if;
      when 1 => if (K = "100" and R = "0001") then nextstate <= 1;
                elsif (K = "000" and R = "0000") then nextstate <= 2;
                else nextstate <= 0;
                end if;
      when 2 to 30 => nextstate <= state + 1;
      when 31 => nextstate <= 0;
    end case;
  end process;

  debug_output: -- display the state
  q <= conv_std_logic_vector(state,5);
end behavior;
end

output_decoder: -- output decoder part
process(state)
begin
  case state is
    when 0 to 1 => UNLOCK <= '0';
    when 2 to 31 => UNLOCK <= '1';
  end case;
end process;

state_register: -- the state register part (the flipflops)
process(clk)
begin
  if rising_edge(clk) then
    state <= nextstate;
  end if;
end process;
end

```

entity
architecture
next_state_decoder:
output_decoder:
state_register:

```

entity
architecture
  next_state_decoder:
  output_decoder:
  state_registers:

```

entity

● **entity** Block-description, input signals and output signals

```

library IEEE;
use IEEE.std_logic_1164.all;
use IEEE.std_logic_arith.all;

start
entity codeLock is
  port( clk:      in  std_logic;
        K:      in  std_logic_vector(1 to 3);
        R:      in  std_logic_vector(1 to 4);
        q:      out std_logic_vector(4 downto 0);
        UNLOCK: out std_logic );
end codeLock;
end

```

The program entity is a description of the code lock as a "black box" with input and output signals.

Bits and Bitvectors

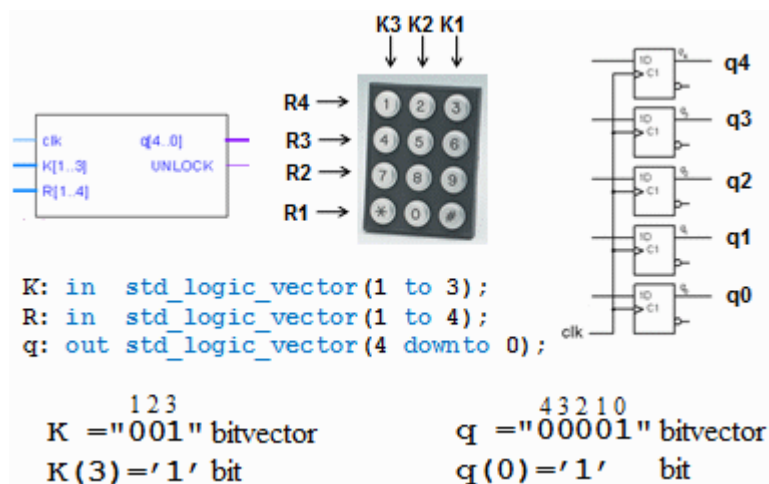

You can customize the indexing of variables so that it is consistent with the data sheets - less risk of mistakes!

Architecture - define suitable datatypes

The program part architecture contains the description of the behavior of the block.

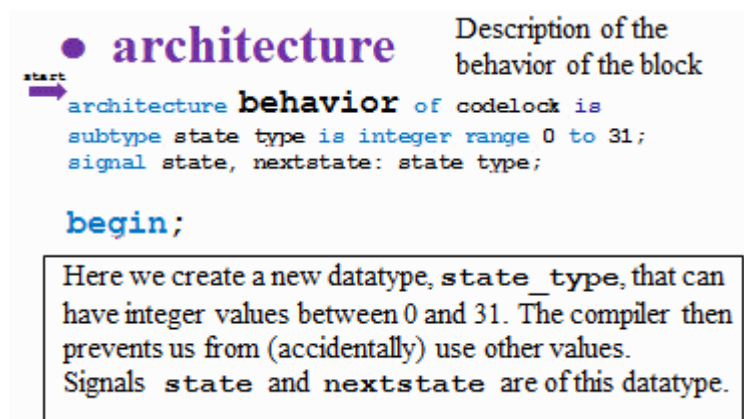

Here we create a new datatype, `state_type`, that can have integer values between 0 and 31. The compiler then prevents us from (accidentally) use other values. Signals `state` and `nextstate` are of this datatype.

Architecture - next state decoder

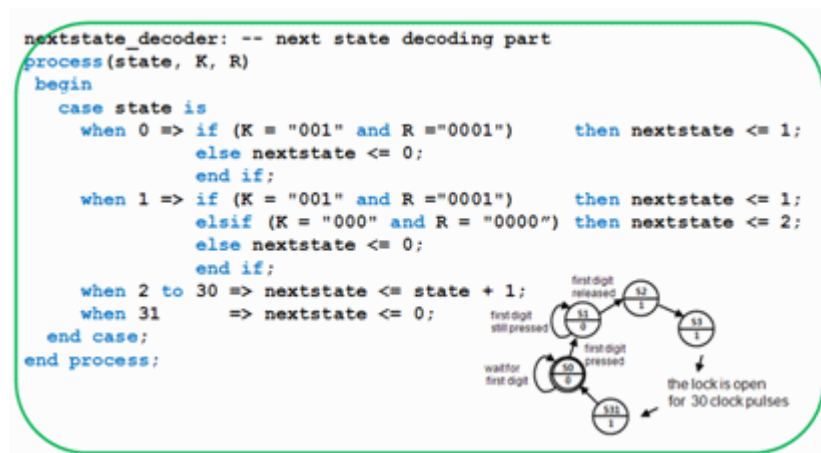

Next state decoder is the central part of the program. By using the case-statement you can write the code in such a way that it conforms to the state diagram.

Troubleshooting help - the state is shown with five LEDs

```
debug output: -- display the state
q <= conv_std_logic_vector(state,5);
```

The function `conv_std_logic_vector()` converts `state` (an integer between 0...31) to a 5-bit bitvector `q`, `q(4) ... q(0)`.

To troubleshoot, we want to be able to follow which state the machine is in. The function `conv_std_logic_vector()` converts `state` (an integer between 0...31) to a 5-bit bitvector `q`, `q(4) ... q(0)`. In order to use this conversion function one has to include the library `IEEE.std_logic_arith.all`.

Output decoder

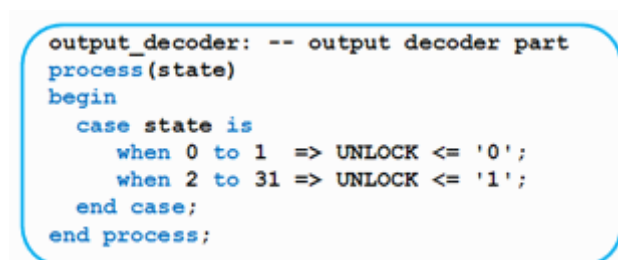

The output decoder is written "straightforward" by a case-statement.

State register

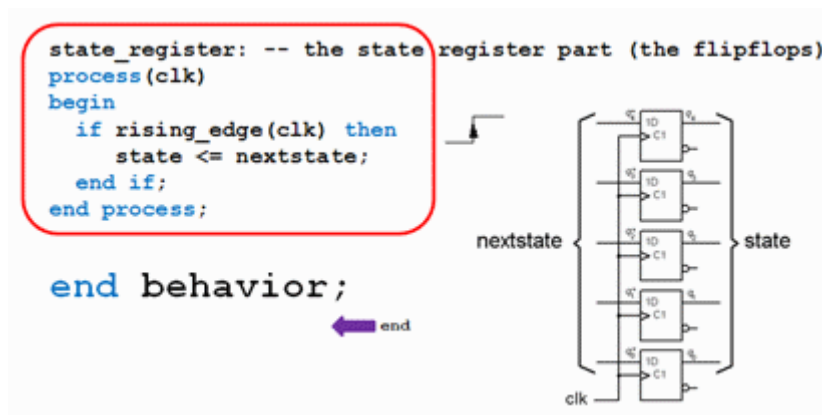

By using the function `rising_edge(clk)` we let the compiler "understand" that we want to use the flip-flops inside the MAX-chip in order to build a register.

VHDL-program with Quartus



Choose the right program version from the school's start menu :

```
Altera 13.0.1.232 Web edition\  
  Quartus II Web Edition 13.0.1.232\  
    Quartus II 13.0sp1 (32bit)
```

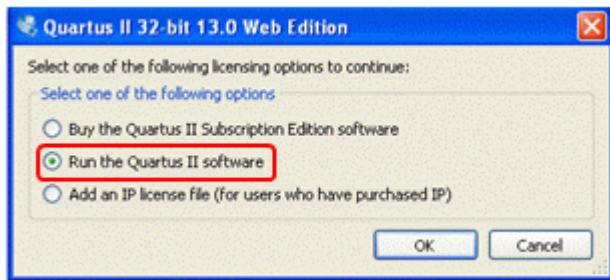

Start Quartus. You need no license and you do not need not buy anything.

If not be directly offered to start **New Project Wizard**, You may also select this option from the **File** menu.

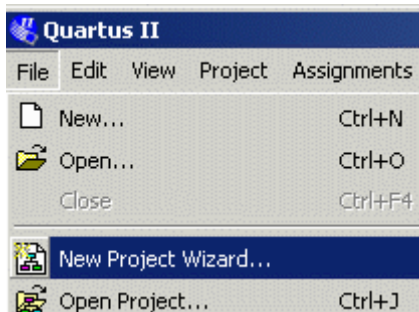

Introduction

Clic on **Next**.

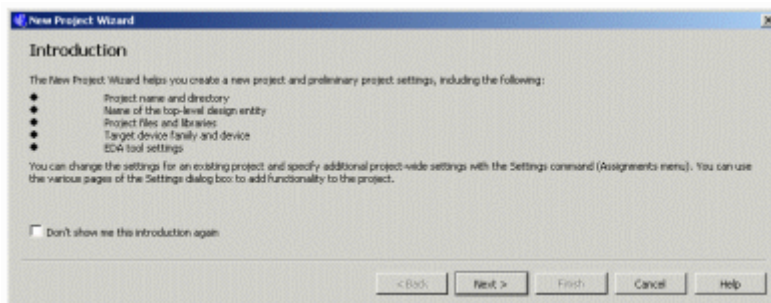

Project Name and Directory

In school, the entire project must be on your H:\, eg. H:\MAXwork (at home on C:\, eg. C:\MAXwork)

Name: `codelock`

Top-Level Entity: `codelock`

(Note! the name `codelock` must "match" the name you later on specify as entity in your VHDL-file)

Proceed with **Next**.

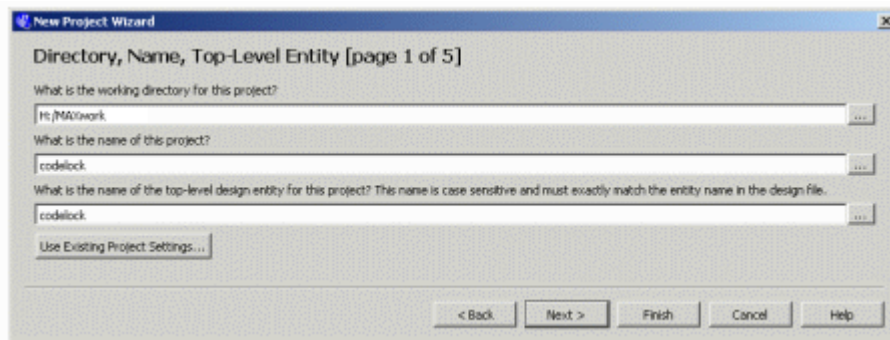

Add files

We have no files to add to the project, so we proceed with **Next**.

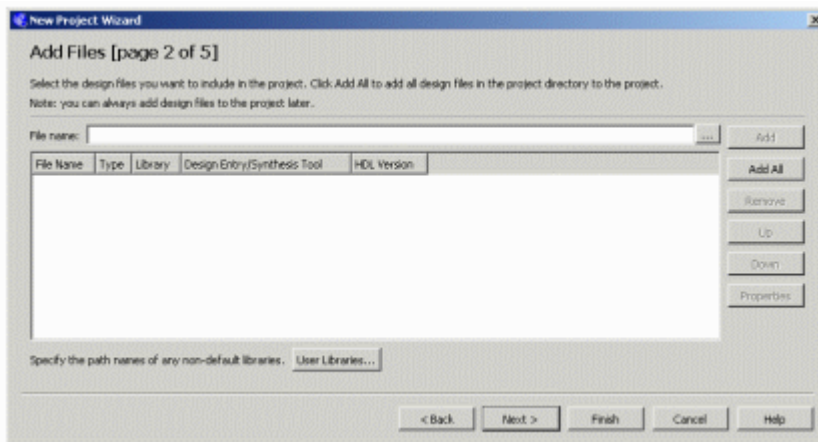

Family and Device Settings

Here we specify which chip we intend to use during the lab.

Family: MAX3000A **Available devices:** EPM3032ALC44-10

Proceed with **Next**.

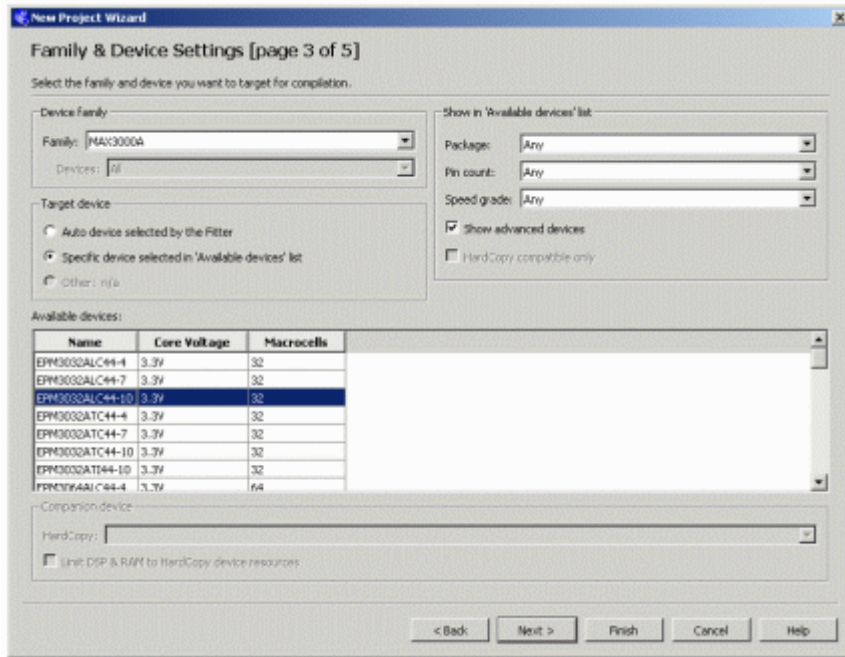

EDA tools setting

Here you can create context with software tools from other vendors. We will simulate with the ModelSim program but that we need not enter. Proceed with **Next**.

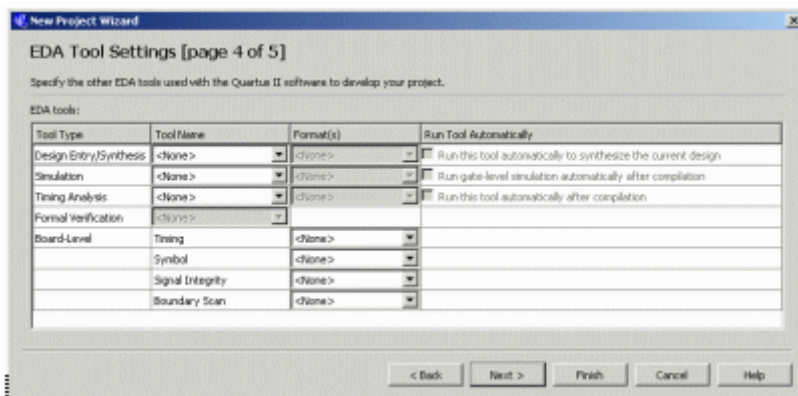

Summary.

Here you can see a summary of your selections, exit the "Wizard" with **Finish**.

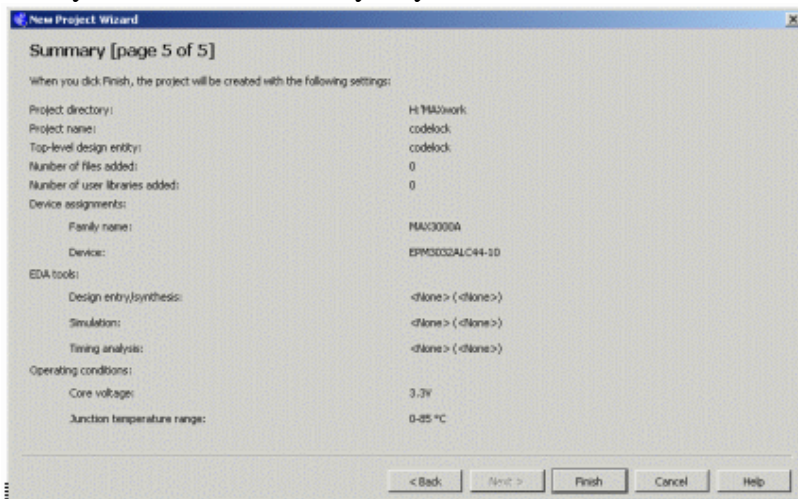

The project has been created

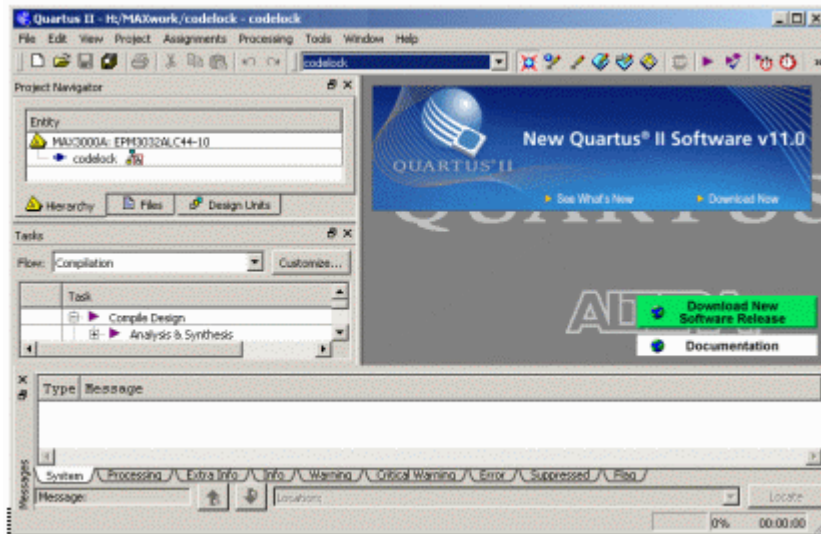

VHDL-code

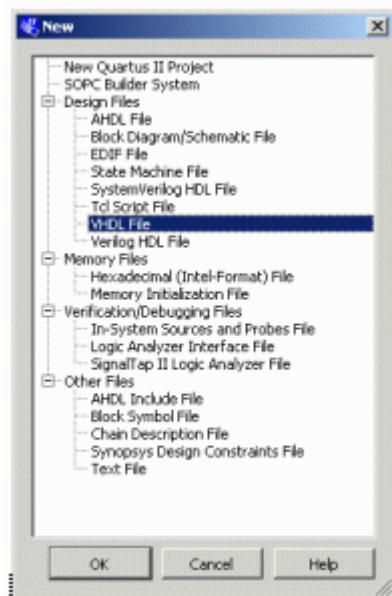

Create a blank file for VHDL-code. **File, New, VHDL File.**

Copy the Template **lockma11.vhd** and paste it in Quartus text editor.

```

library IEEE;

use IEEE.std_logic_1164.all;
use IEEE.std_logic_arith.all;

entity codelock is
  port( clk:      in  std_logic;
        K:      in  std_logic_vector(1 to 3);
        R:      in  std_logic_vector(1 to 4);
        q:      out std_logic_vector(4 downto 0);
        UNLOCK: out std_logic );
end codelock;

architecture behavior of codelock is
  subtype state_type is integer range 0 to 31;
  signal state, nextstate: state_type;

begin
  nextstate_decoder: -- next state decoding part
  process(state, K, R)
  begin
    case state is
      when 0 => if (K = "001" and R = "0001")      then nextstate <= 1;
                else nextstate <= 0;
                end if;
      when 1 => if (K = "001" and R = "0001")      then nextstate <= 1;
                elsif (K = "000" and R = "0000") then nextstate <= 2;
                else nextstate <= 0;
                end if;
      when 2 to 30 => nextstate <= state + 1;
      when 31 => nextstate <= 0;
    end case;
  end process;

  debug_output: -- display the state
  q <= conv_std_logic_vector(state,5);

  output_decoder: -- output decoder part
  process(state)
  begin
    case state is
      when 0 to 1  => UNLOCK <= '0';
      when 2 to 31 => UNLOCK <= '1';
    end case;
  end process;

  state_register: -- the state register part (the flipflops)
  process(clk)
  begin
    if rising_edge(clk) then
      state <= nextstate;
    end if;
  end process;
end behavior;

```

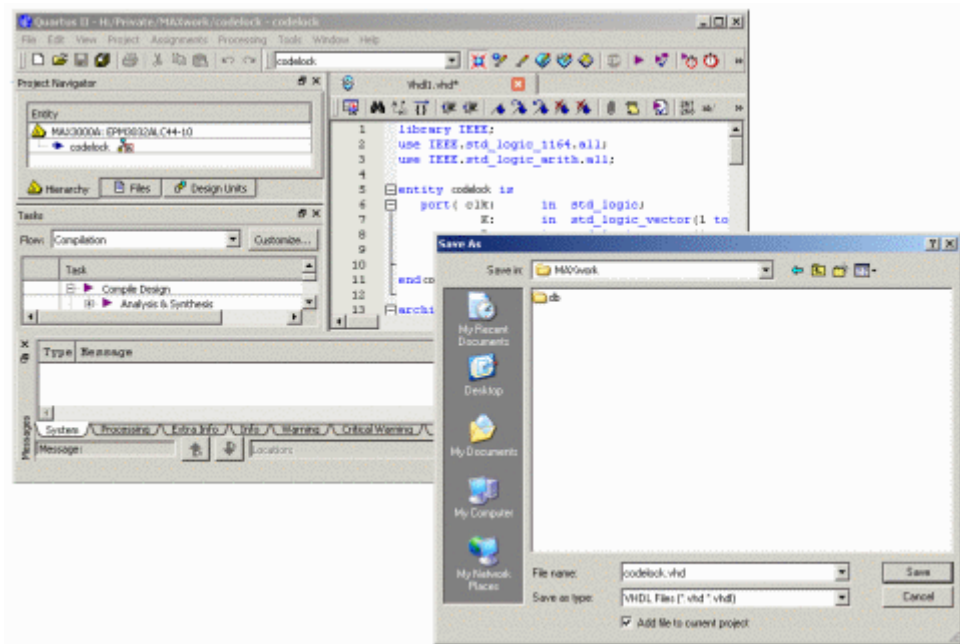

Note that entity in the VHDL-file must "match" the project Top Level Entity!

Save the file: **File, Save As** and as VHDL-file. The name could be codeLock.vhd (or another).

Add File to current project shall be checked!

Analysis and Synthesis

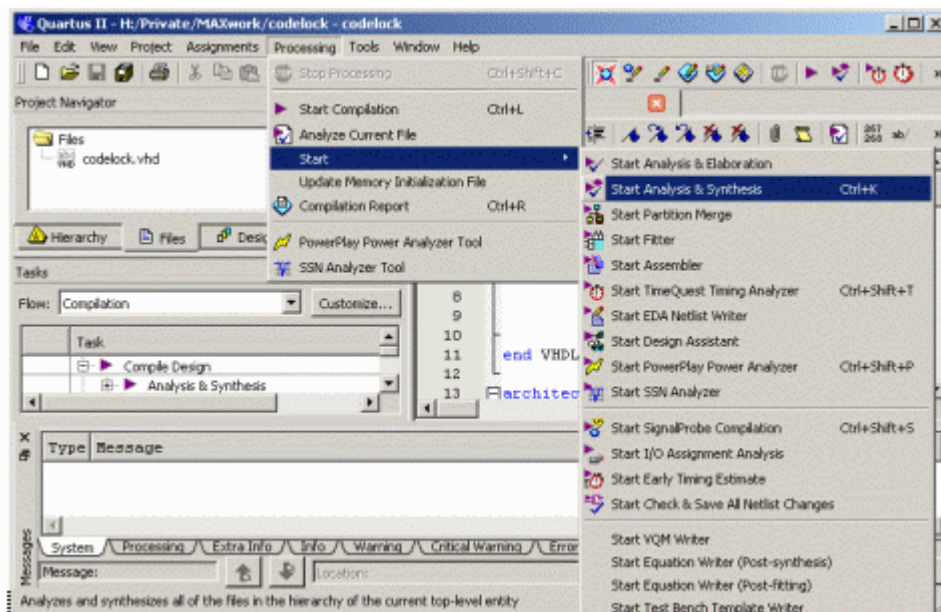

When you have new code, it is unnecessary to run the entire tool chain - chances are that there are errors along the way ...

From the start you only do Analysis & Synthesis.

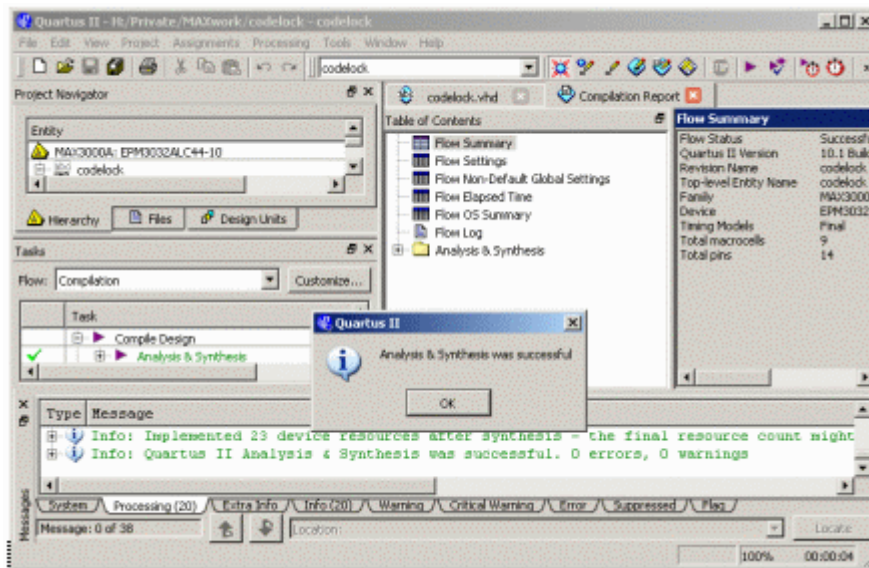

Start Compilation

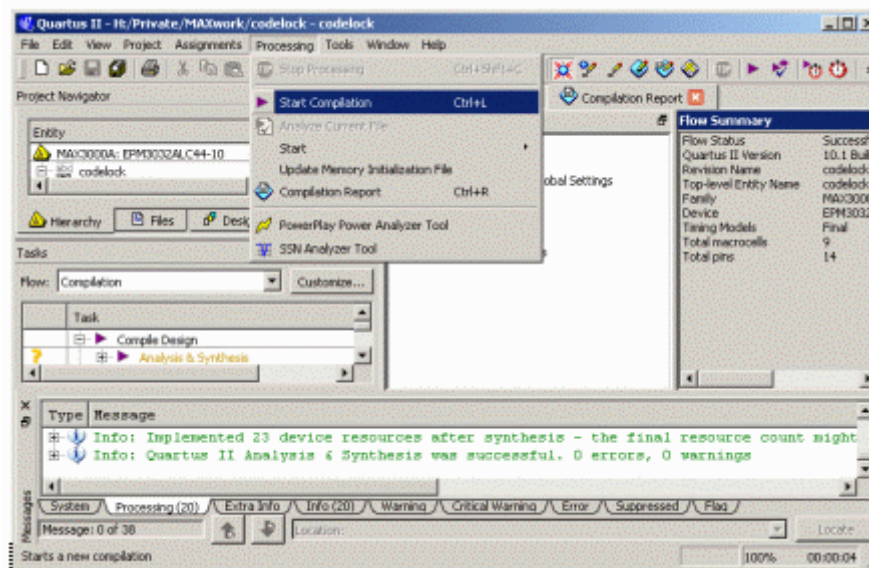

Start Compilation runs the full tool chain.

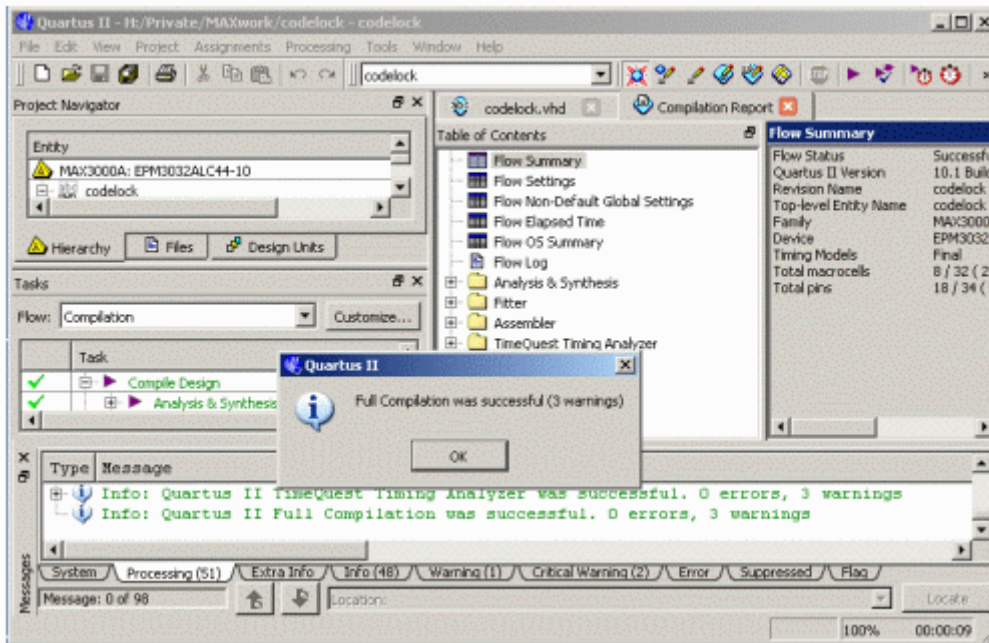

The 3 warnings (moore with other program versions) are about "software tools" that are missing in our program version but we don't need them.

Pin-planning in Quartus

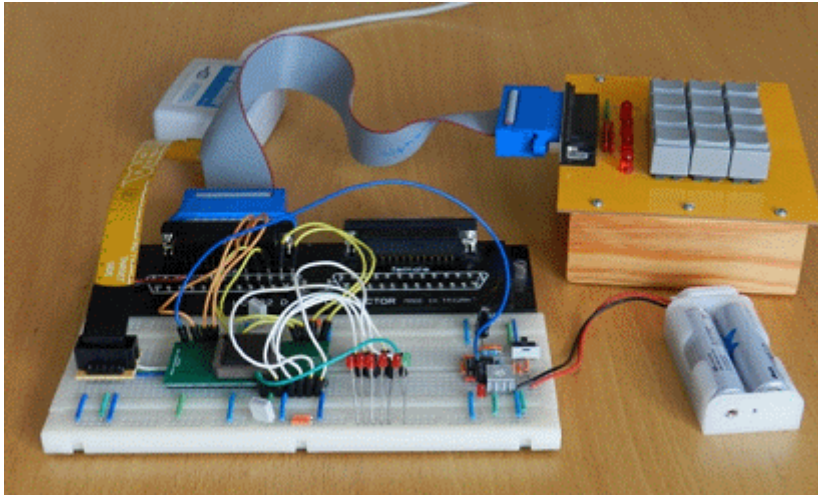

The lab code locks has different wiring. MAX chips must therefore be programmed differently to fit the equipment.

Quartus has a Pin-planning function. Either you can let the compiler choose pins for the various signals - And then adapt the wiring after this, or the wiring is determined in advance (which is the case here) and then you have to self pair signals with pins.



Start Pin Planner. Menu **Assignments**, choose **Pin Planner**, or by clicking on the icon for Pin Planner.

You write the pin-number you want to assign in the column **Location**. Double click in the box to get a list of possible pins. In the column **Fitter Location** shows which pin the autofitter function has selected - but it is usually possible to make other choices yourself.

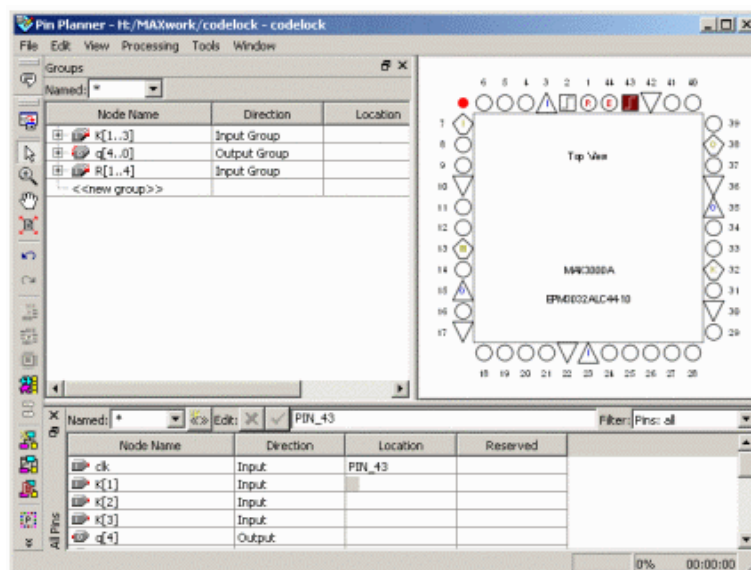

In the pin planner there is a picture of the pin layout for the selected chip, and a list of the variables/signals that has occurred in the VHDL code.

MAX3000-chip has 44-pin. Some of them are occupied for supply voltages. Often MAX circuits are used to connect digital equipment using different supply voltages, but since we do not have such needs, we have linked all those pins to the same supply voltage + 3V.

Other pins are used for chip programming, they are connected to the so-called JTAG connector (TDI TMS TCK TDO).

There are two clock inputs, one enable input and one reset input. Pin that are not used can be left unattended because the compiler makes sure they are disconnected.

Total remains 26 user defined pins, to freely use as inputs or outputs.

Connections to the lab breadboard

The keys on the keyboard are arranged as a matrix with four rows and three columns as a total of seven lines, connected to a DB-25 connector. The output signal is one yellow LED, and five red LEDs used to present the code lock internal state.

Symbol	Pin Type
○	User I/O
●	User Assigned I/O
●	Fitter Assigned I/O
○	Unbonded Pad
●	Reserved Pin
ⓔ	DEV_OE
Ⓡ	DEV_CLR
⏏	CLK
⏏	TDI
⏏	TCK
⏏	TMS
⏏	TDO
⏏	VCCINT
⏏	VCCIO
⏏	GND

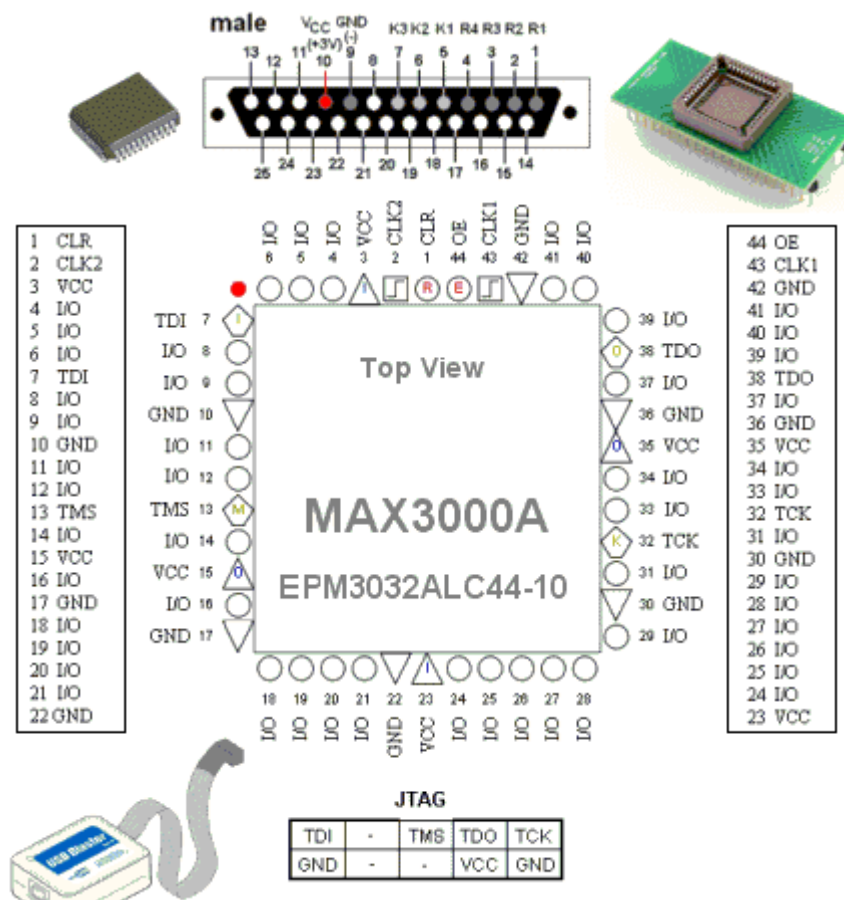

MAX-chip is contained in a TQFP-44 package. To use the MAX circuit on a breadboard, we have acquired an adapter, a breakout-board, which has pins positioned as a DIL-44 chip. The figure shows the pin placement on the MAX-chip and on the breadboard.

MAX-chip has many voltage connections. You can take them to help orient you on the breadboard.

(3 VCC, 10 GND, 15 VCC, 17 GND, 22 GND, 42 GND, 36 GND, 35 VCC, 30 GND, 23 VCC.)

Lab assistants has access to **facit-files** for the different lab equipment versions. With them, we can quickly rule out possible problems, eg. if you have entered the pin numbers incorrectly.

Chip-programing with Quartus

Choose chip programming equipment - USB-Blaster



Connect the USB blaster to your computer. Connect the USB Blaster JTAG connector to lab equipment. Note! The lab equipment's voltage shall be off when plugging in or unplugging the JTAG connector. Lab equipment's voltage must be turned on when you program the chip - USB power alone is not enough for this.



From within Quartus, select the menu item **Tools** and **Programmer**, or you clic the icon Programmer.

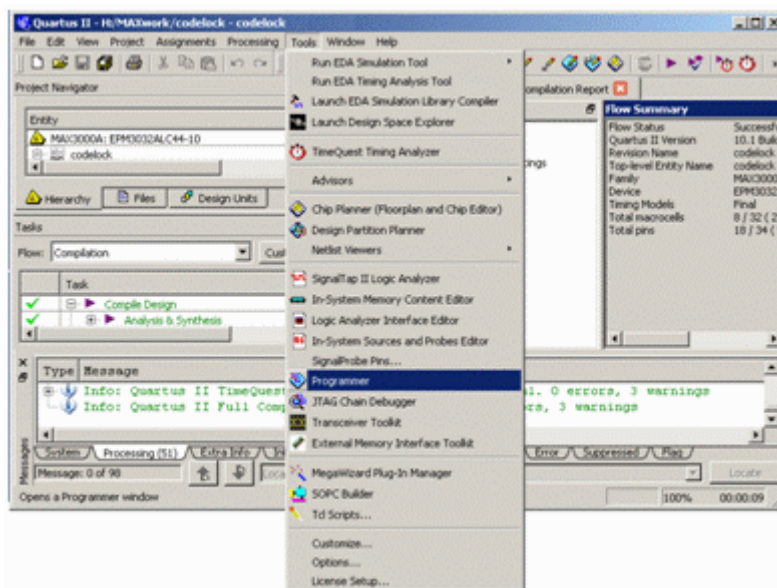

In the window **Programmer** you click on **Hardware Setup** in order to select the USB blaster as the programming equipment. (The computer then remembers this setting)

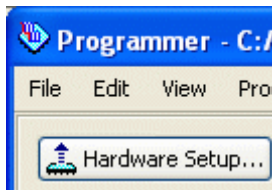

In the window **Hardware Setup** there is a list of "Available hardware items". There stands USB blaster. (If not then you may have forgotten to plug it?) Select USB-blaster and clic on **Add Hardware**.

Now the USB-blast should be your "Currently selected hardware". click on **Close**. Quartus will remember your choice, so probably you do not need to repeat this one more time.

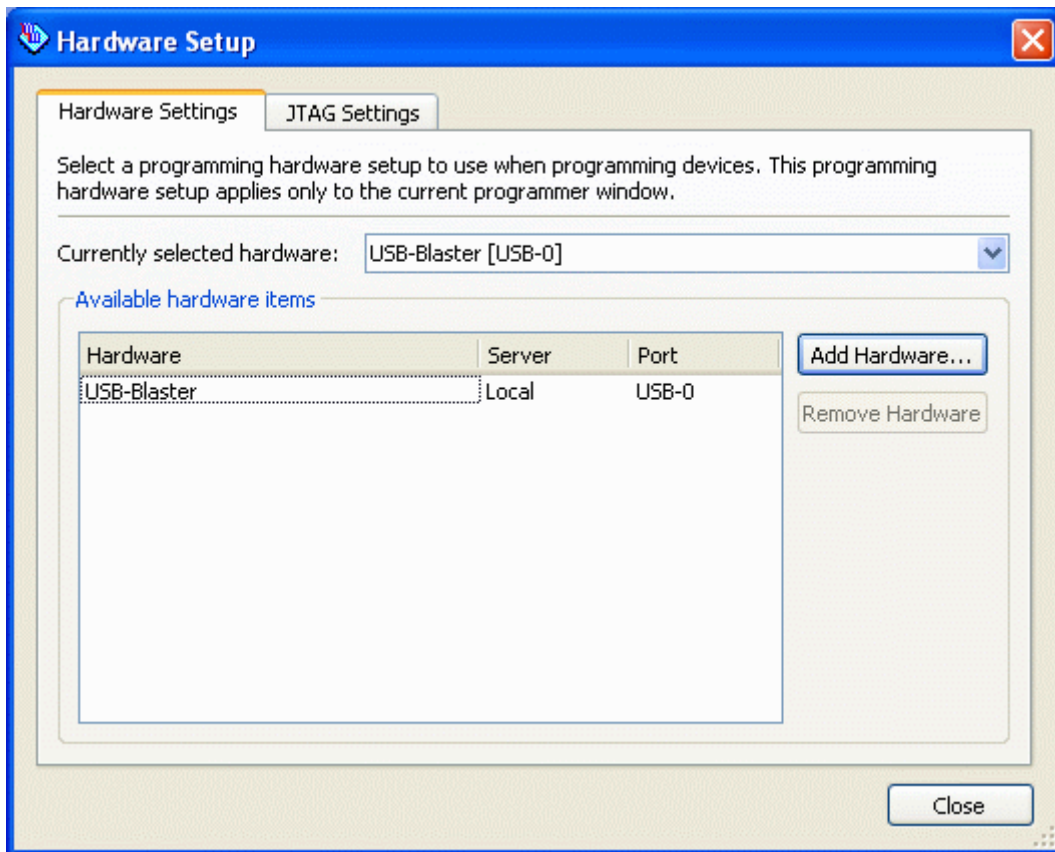

In the window **Programmer** you can see what hardware (chip) that is selected.

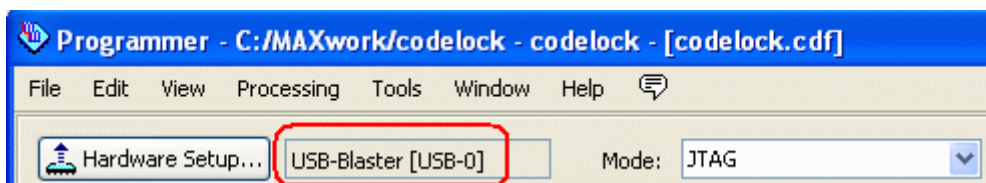

Download the code to the chip

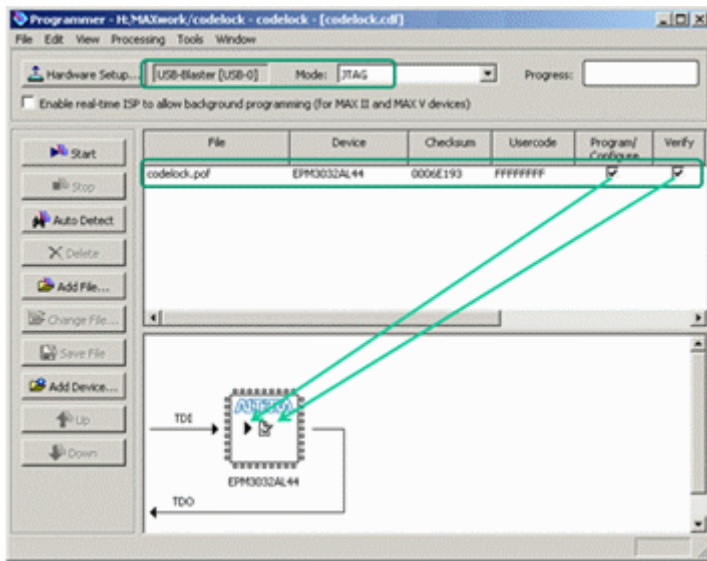

The compiled program is in a *.pof-file. Browse to it with **Add File ...** (it is probably in a subfolder `output_files`) and choose the file.

The compiled project name is now in the box **File**.

Check **Program/Configure** and **Verify**. In the picture with the chip there is now emerging symbols of your choices.

It is possible to program many chips in the same equipment. The picture then shows a daisy chain of the chips that can be programmed, one at a time with different code.

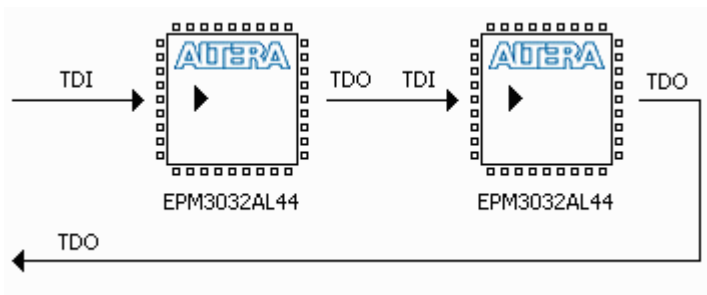

We only have one chip, and you start programming by clicking on the **Start** button. Attention! Do not forget that the power to the lab card should be on during programming!

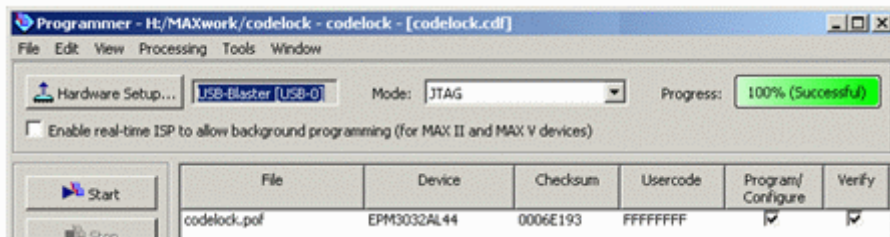
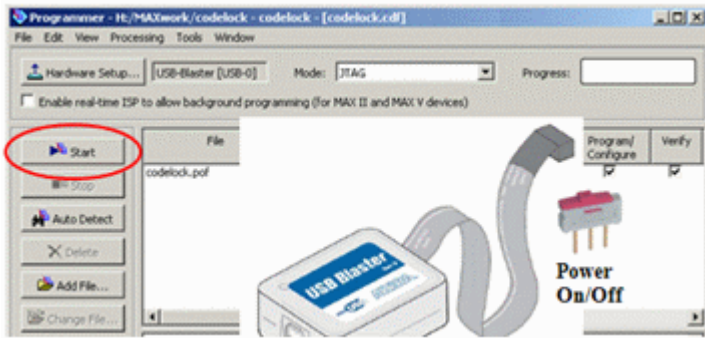

Try twice if it does not work - then contact the lab assistant.
The most common problem is a bad battery.

Simulate with ModelSim



ModelSim - simulation software

ModelSim can be used to simulate VHDL-code, to determine whether it is "right" thinking. The Altera version of **ModelSim** is also integrated with a "database" with facts about Altera-chips, eg. MAX-chips, so one can also do simulations that take into account the "time delay" and other phenomena within the intended target circuit. (As long as the target circuit is of Altera's brand ...).



Select the correct software version - in school there are several versions installed in the Start menu!

```
Altera 13.0.1.232 Web edition\  
  ModelSim-Altera Starter Edition 13.0.1.232\  
    ModelSim-Altera 10.1d(Quartus II 13.0sp1)
```

Start **ModelSim**.

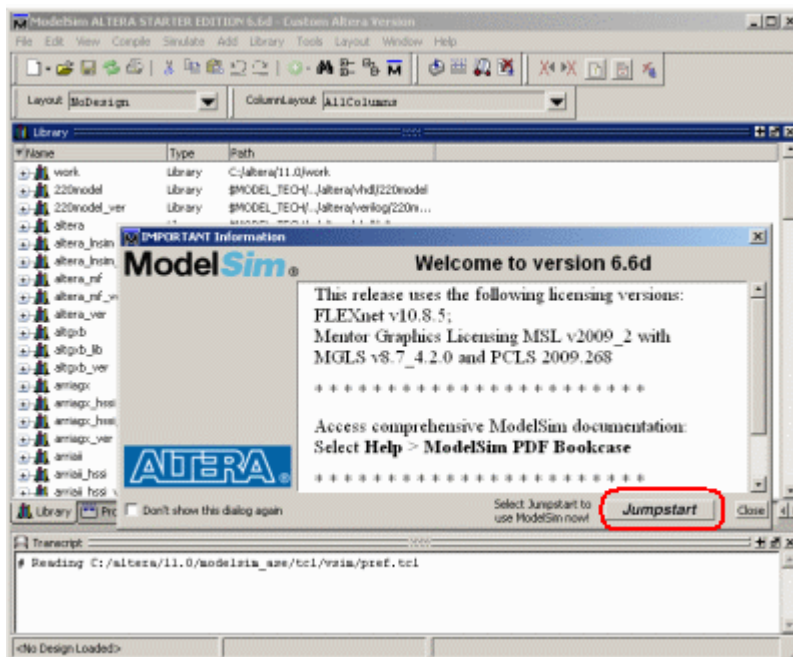

In the window "important information" you click on **Jumpstart** to get help with setting up a project.



Then you click on "Create a Project" in the welcome window.

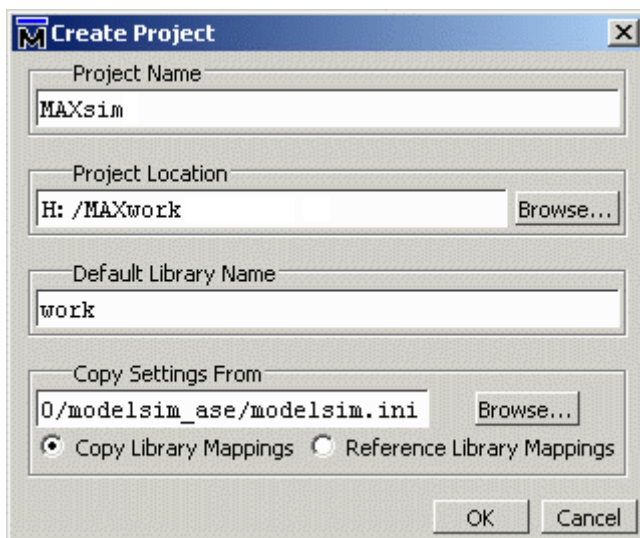

Create a project.

Project Name

MAXsim can be a suitable name

Project location

H: /MAXwork browse to the same folder you used for Quartus.

Default Library Name

work keep the suggested name, it's the standard at VHDL-simulation

Klicka på **OK**.

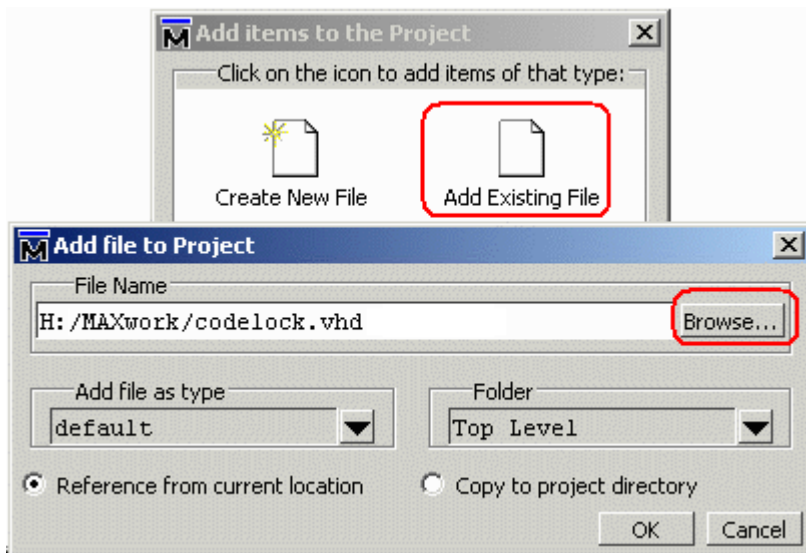

We choose "Add Existing File" to add a VHDL-file to the project.
 "Browse" to the file `codelock.vhd` that we created earlier with **Quartus**.

Click on **OK**. Then click on **Close**.

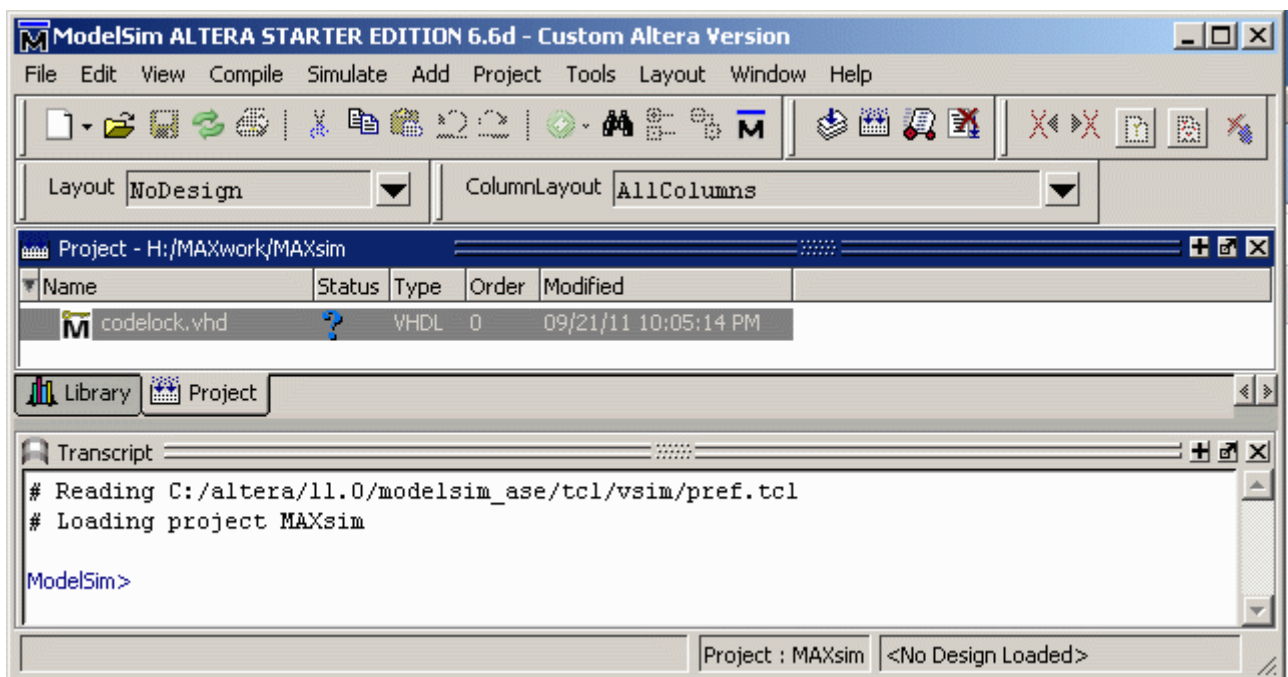

Codeclock code in ModelSim



ModelSim has a *own* compiler to produce the code for simulation. Though we have compiled the VHDL code in **Quartus** we must now compile it again for **ModelSim**.

Name	Status
codelock.vhd	?

Choose **Compile** menu, alternative **Compile All**.

Name	Status
 codelock.vhd	

Now the VHDL-code is also compiled for **Modelsim**.
Status symbol changes from a blue question mark to a green check!

Simulate codelock-template!

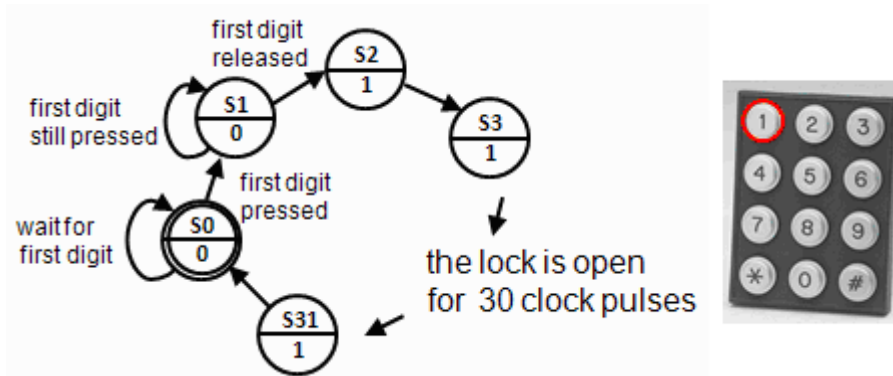

We simulate by giving different commands in the **Transcript**-window, and then follow some selected signals in the window **Wave**.

Transcript-window is a terminal window where you enter commands, but you can also give most commands by menu selection, or by clicking on buttons. Commands are always written in the **Transcript**-window, regardless of how they are given.

Load the Design to simulator..

Choose the tab **Library**, and open the folder **work**. Doubleclick on "Entity" `codelock`. A series of commands are now executed resulting in that the design is loaded into the simulator.

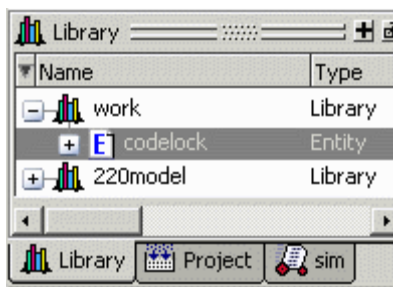

In the **Transcript**-window you can follow the commands executed.

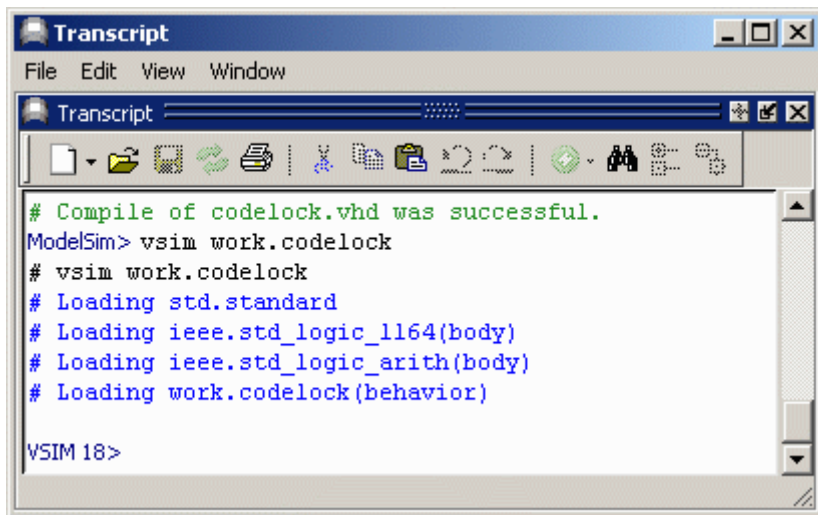

Prepare simulation

We need to have a number of windows open in order to follow the simulation.

Give these commands in **Transcript**-window or check in the **View**-menu.

```
VSIM> view objects
VSIM> view locals
VSIM> view source
VSIM> view wave -undock
```

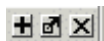
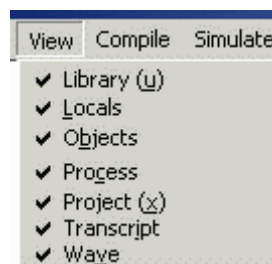

Modelsim consists of "windows". It can be hard to see everything at the same time. With the button **Zoom/Unzoom** you can enlarge the window. With the button **Dock/Undock** the window can be moved to any location, it is that alternative we choose for **Wave**-window. With the button **Close** those windows not needed for the time can be closed.

Signals in Wave window

If you have many signals, it is a good idea to select the signals you are interested to follow in **Wave**-window, but this time we choose to follow them all:

```
add wave *
```

There are several ways to add signals to the **Wave**-window:

- Select signals in **Object**-window (Shift+Left Button) and "drag and drop" the selection to **Wave**-window.
- Right-click in the **Object**-window and choose **Add to Wave**.
- A **Add to Wave** dialoge-window is reachable from the menu, **Add**.

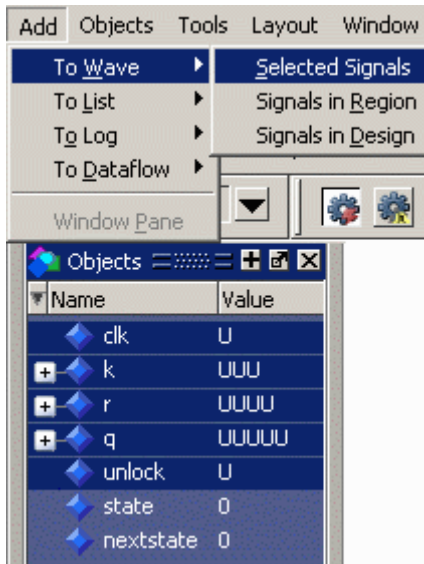

Format, Radix, Hexadecimal

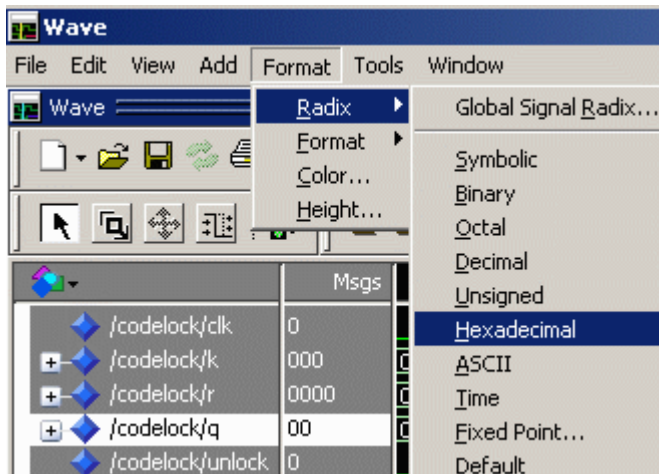

The state variable `q` has 32 different states, such a variable is easier to follow if it is presented as a hexa-decimal number, `00 . . . 1F` instead of a binary number. We therefore suggest that you check the variable and change the presentation to hexadecimal. `UUUUU` is exchanged to `XX` in the **Wave**-window. Other variables are best suited to be presented as binary numbers.

Create stimuli

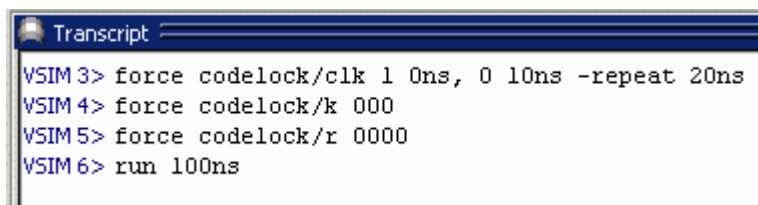

The default time resolution in **Wave** is nanoseconds, `ns`. A suitable clock frequency for a code lock may however be as low as 5 Hz, or a period time of 0.2 sec.

The easiest way, of not having to make extensive adjustments of the program, is to "scale"

our problem to a higher clock speed with a period of 20 ns. We then has to imagine that there are fast fingers that press the keys!

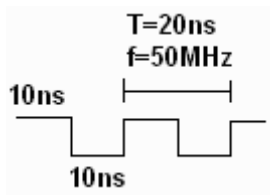

Stimuli, Inputsignals as clock pulses or key-presses, are created with the command `force` in the **Transcript**-window.

```
force codelock/clk 1 0ns, 0 10ns -repeat 20ns
```

Generates clockpulses for ever.

```
force codelock/k 000
force codelock/r 0000
```

Initiates variables r and k.

```
run 100ns
```

Runs the simulation in 100 ns, which is five clock cycles.

Simulate keypresses

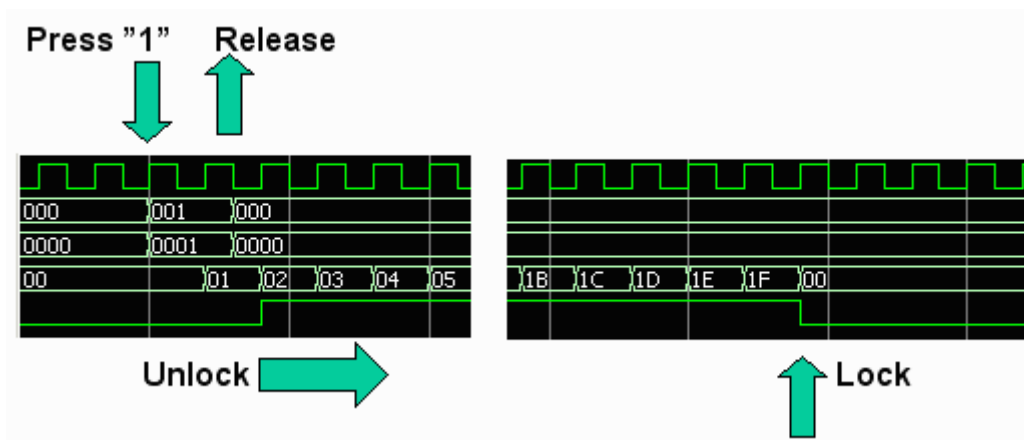

```
force codelock/k 001
force codelock/r 0001
run 30ns
force codelock/k 000
force codelock/r 0000
run 800ns
```

30 ns (20+10) means that the keypress is certain be in the gap between the clock edges. The full simulationtime 100 ns +30ns + 800 ns = 930 ns corresponds to 46.5 clock pulse periods. This is enough to show the lock's entire opening sequence.

Do-file

Transcript-window, you can run many commands in sequence from a Do-file.

Alternatively, you can copy the text in Windows (Ctrl-C) and paste it (Ctrl-V) in **Transcript**.

```
delete wave *
add wave codelock/clk
add wave codelock/k
add wave codelock/r
add wave codelock/q
add wave codelock/unlock
force codelock/clk 1 0ns, 0 10ns -repeat 20ns
force codelock/k 000
force codelock/r 0000
run 100ns
force codelock/k 001
force codelock/r 0001
run 30ns
force codelock/k 000
force codelock/r 0000
run 800ns
```

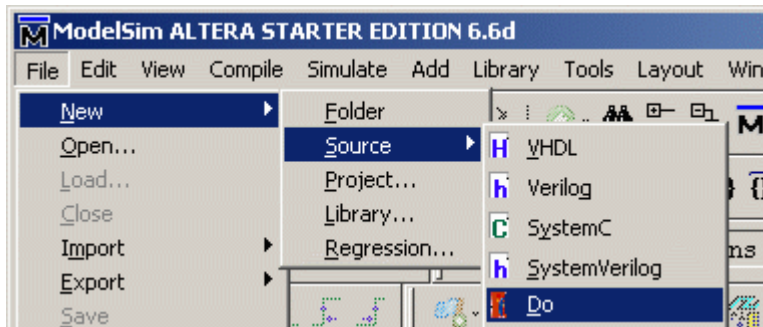

This is how to create a Do-file. Paste text commands above in the file. Then save it among the other files (in MAXwork) with extension `.do`.

You run a Do-file with these commands (in **Transcript**):

```
restart -f
do lock.do
```

Find in the Wave window

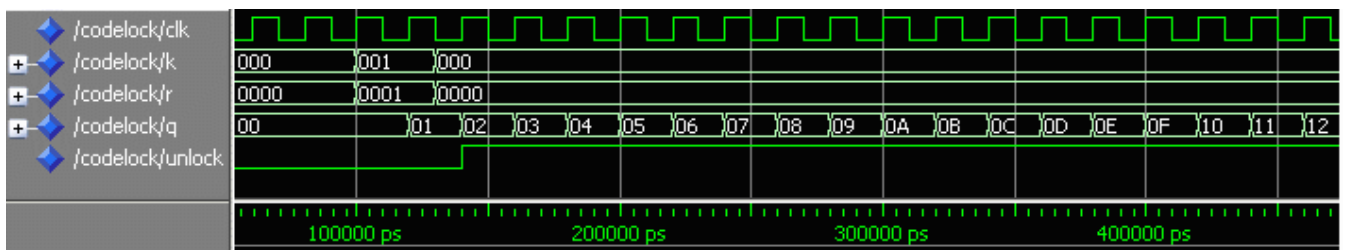

It can be difficult to find what you are looking for in the Wave window. Therefore, there is a whole series of tools like Zoom, Expanded time, Cursors ...

Add, Cursor.

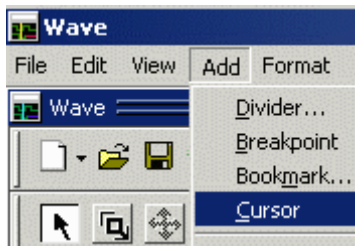

A Cursor can be used together with the function **Edit, Wave Signal Search**.

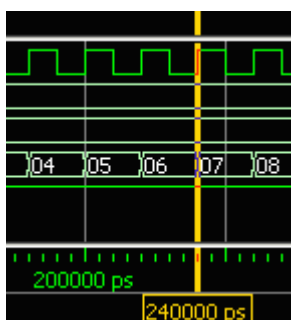
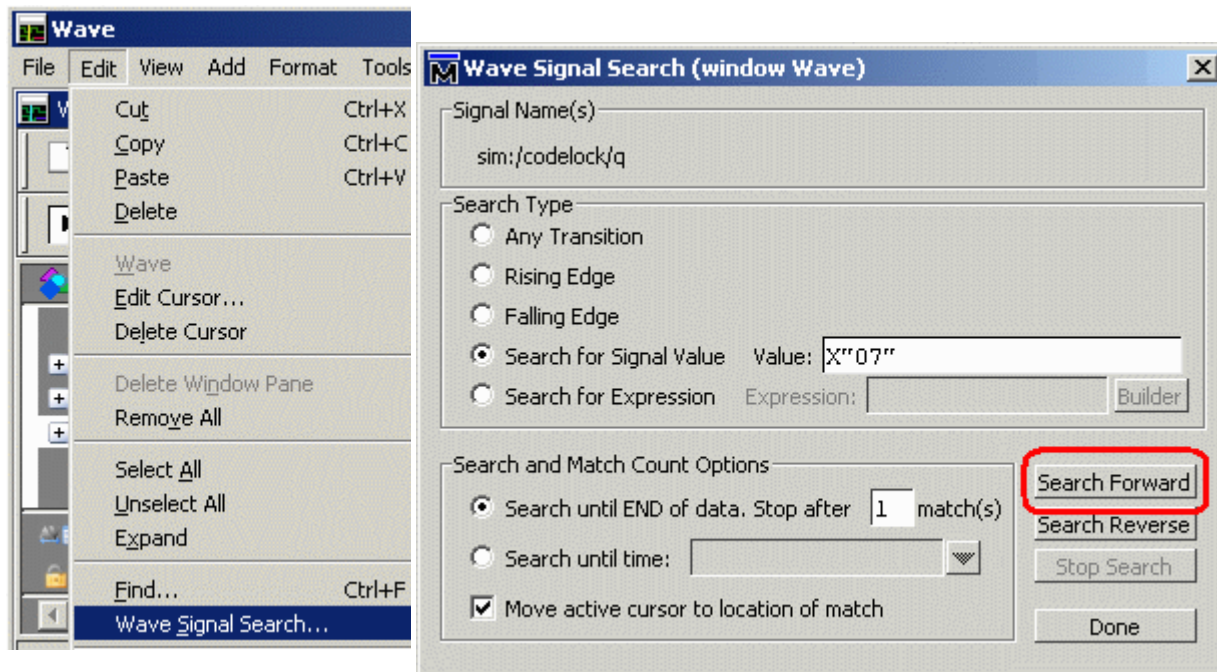

Now the Cursor points what happens (this time nothing special!) when q has the state 07.

Spend a little time now to try different tools available for orientation in Wave Window!

The simulation has shown that the lock opens to the intended key-press, but this is not enough - There is need for more "testing" before one can trust the construction!

Testbench in ModelSim



Select the correct software version - in school there are several versions installed in the Start menu!

```
Altera 13.0.1.232 Web edition\  
  ModelSim-Altera Starter Edition 13.0.1.232\  
    ModelSim-Altera 10.1d(Quartus II 13.0sp1)
```

Start **ModelSim**.

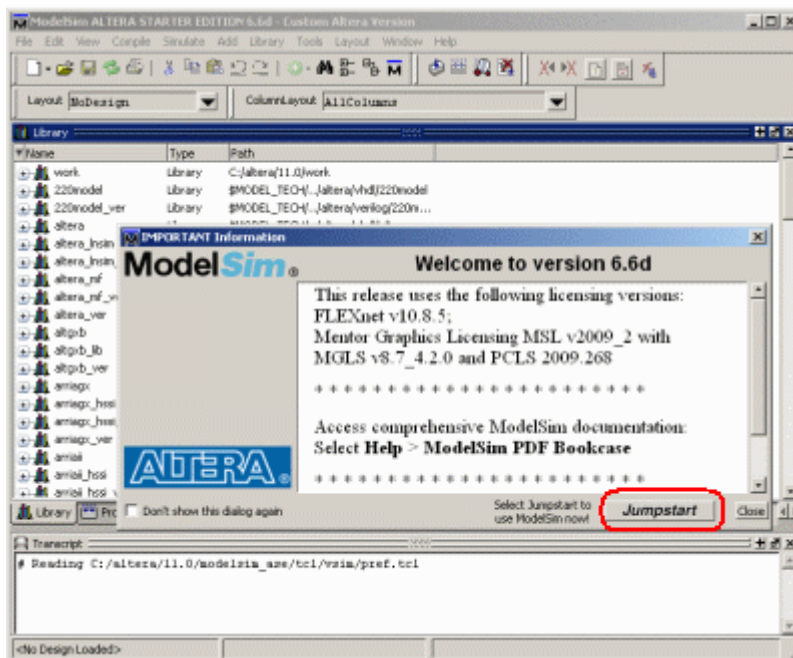

Klicka på **Jumpstart**. This time we choose "Open Project" for continue with our previous MAXsim-project.



Testbench

In addition to the VHDL code for the lock, we now need another VHDL file for the test bench code.

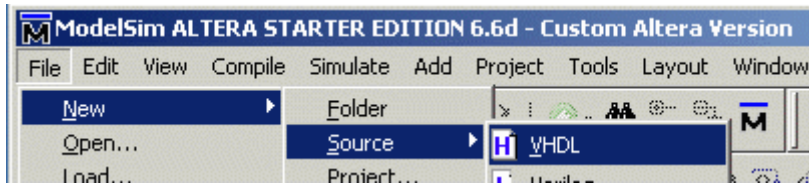

Create a new empty VHDL-file. Copy and paste the content of the file `tb_lockmall.vhd` and then save the file using the same name, `tb_lockmall.vhd`, among the other files in the project.

Alternatively, you can copy the file `tb_lockmall.vhd` to the folder with the other files of the project.





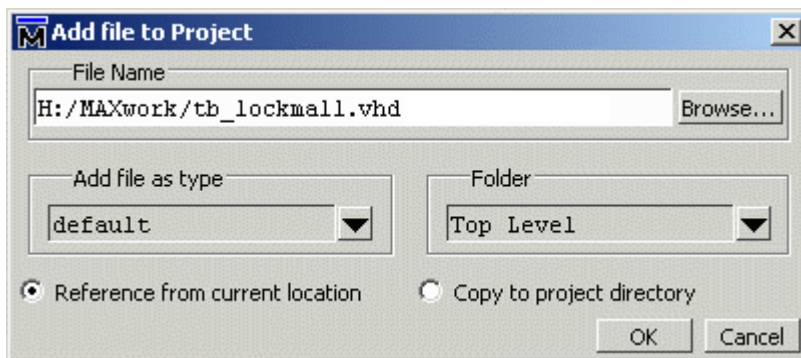
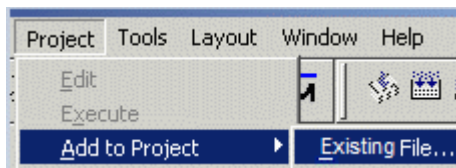

Add the VHDL-file to the project

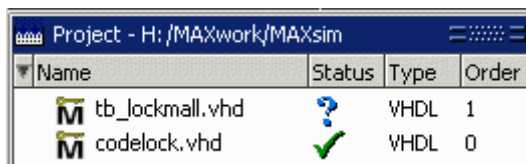

The project now has two files. The file `tb_lockmall.vhd` is not compiled yet, which can be seen on the blue question mark.



Choose the menu **Compile** and the alternative **Compile All**. Now the file is compiled `tb_lockmall.vhd`. By the content of the file we can see that it controls the other file `codelock.vhd`, so that's why it gets the highest order.

Name	Status	Type	Order
 tb_lockmall.vhd		VHDL	1
 codelock.vhd		VHDL	0

Load the Design to the simulator.

We want to test the bench messages to appear (as arrows) at the top of the **Wave**-window. Therefore, we write in the **Transcript** window:

```
vsim -msgmode both -displaymsgmode both tb_codelock
```

Then add the signals in the **Wave**-window.

```
add wave *
```

Start simulation

In the file `tb_codelock.vhd` you find `clk <= not clk after 10 ns;`. It creates the clock pulses with a period of 20 ns, as we used before.

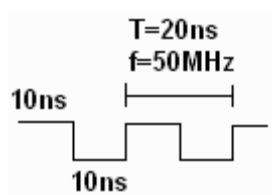

We can immediately start the simulation with the command `run 3us` in the **Transcript**-window. The time 3 μs sufficient to try all possible key-press combinations.

In the **Transcript**-window we can read the encouraging message `Note: Lock tries to open for the right sequence!`.

In **Wave**-window choose **View**, **Zoom**, and **Zoom Full** and then you can see the entire process.



The green arrows show the *when* the desired event happens! Now exit the simulation.

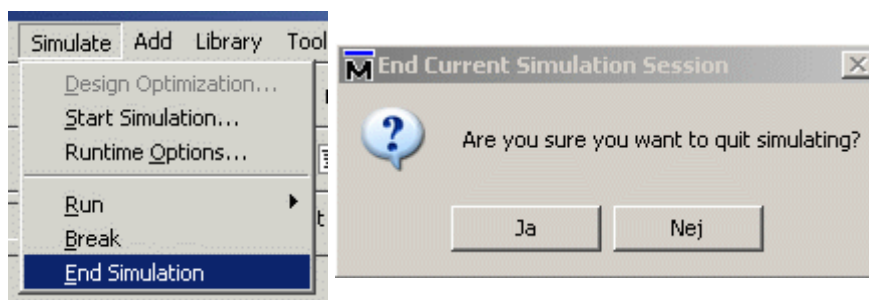

Reveal the wrong code!

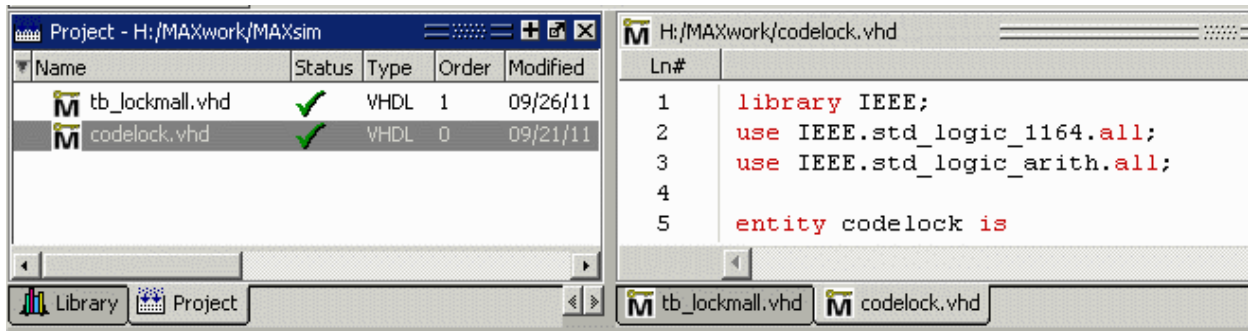

Now we need to in **Project** window, double-click the file `codelock.vhd` so that it appears in the text editor where we can change it. Copy and paste the content of the file `lockmall_with_error.vhd`. Then save the file under the same name as before and recompile everything.

 [lockmall_with_error.vhd](#) ( [lockmall_with_error.txt](#))

Simulate in the same way as before. In **Transcript**-window you can read the message from the test bench when event happens!

The red arrow in the **Wave**-window shows *when/where* the undesired event happens!



VHDL-test bench file

You do not of course be able to write a VHDL Test Bench file after a short first course on Digital Design. Still take the opportunity to go through the file and see if you can understand how it is intended!

Se **VHDL testbench file**

VHDL Testbench for ModelSim



Template -program action

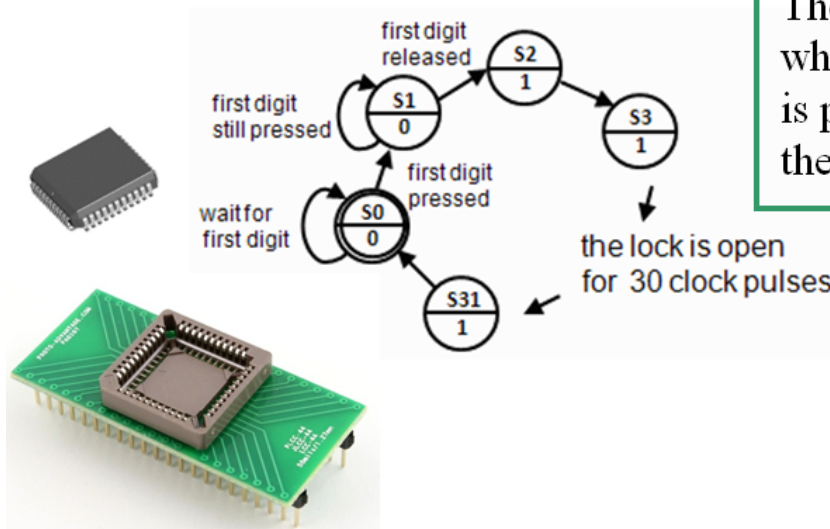

The lock opens when the key "1" is pressed and then released.

Keypad and Statecounter

Good choice of data types makes the code self-explanatory!

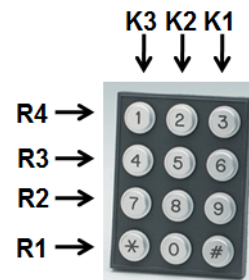
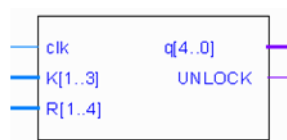

```
K: in std_logic_vector(1 to 3);
R: in std_logic_vector(1 to 4);
```

```
1 2 3          1 2 3 4
K = "001" bitvector    R = "0001" bitvector
K(3) = '1' bit        R(4) = '1' bit
```

```
4 3 2 1 0
Statecounter: q = "00001" bitvector
q(0) = '1' bit
```

This code is given



```
library IEEE;
use IEEE.std_logic_1164.all;
use IEEE.std_logic_arith.all;

entity codelock is
  port( clk:      in  std_logic;
        K:      in  std_logic_vector(1 to 3);
        R:      in  std_logic_vector(1 to 4);
        q:      out std_logic_vector(4 downto 0);
        UNLOCK: out std_logic );
end codelock;
```

```
architecture behavior of codelock is
  subtype state_type is integer range 0 to 31;
  signal state, nextstate: state_type;
```

```
begin
  nextstate_decoder: -- next state decoding part
  process(state, K, R)
```

```
begin
  case state is
    when 0 => if (K = "100" and R = "0001") then nextstate <= 1;
              else nextstate <= 0;
              end if;
    when 1 => if (K = "100" and R = "0001") then nextstate <= 1;
              elsif (K = "000" and R = "0000") then nextstate <= 2;
              else nextstate <= 0;
              end if;
    when 2 to 30 => nextstate <= state + 1;
    when 31 => nextstate <= 0;
  end case;
end process;
```

```
debug_output: -- display the state
q <= conv_std_logic_vector(state,5);
```

```
output_decoder: -- output decoder part
process(state)
begin
  case state is
    when 0 to 1 => UNLOCK <= '0';
    when 2 to 31 => UNLOCK <= '1';
  end case;
end process;
```

```
state_register: -- the state register part (the flipflops)
process(clk)
begin
  if rising_edge(clk) then
    state <= nextstate;
  end if;
end process;
end behavior;
```

It's easy to see that this is correct!

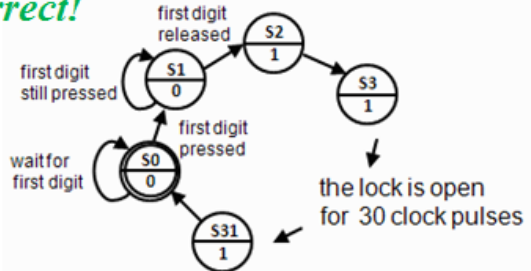

lockmall_with_error.vhd

```
library IEEE;
use IEEE.std_logic_1164.all;
use IEEE.std_logic_arith.all;

entity codelock is
  port( clk:      in  std_logic;
        K:      in  std_logic_vector(1 to 3);
        R:      in  std_logic_vector(1 to 4);
        q:      out std_logic_vector(4 downto 0);
        UNLOCK: out std_logic );
end codelock;
```

```
architecture behavior of codelock is
  subtype state_type is integer range 0 to 31;
  signal state, nextstate: state_type;
```

```
begin
  nextstate_decoder: -- next state decoding part
  process(state, K, R)
```

```
begin
  case state is
    when 0 => if(((R(2)='0') and (R(3)='0') and (K(2)='0') and (K(3)='1')) and
                (not ((not ((K(1)='0') and (R(1)='0') and (R(4)='1')) and
                (not ((K(1)='1') and (R(1)='1') and (R(4)='0'))))))))
              then nextstate <= 1;
              else nextstate <= 0;
              end if;
    when 1 => if(((R(2)='0') and (R(3)='0') and (K(2)='0') and (K(3)='1')) and
                (not ((not ((K(1)='0') and (R(1)='0') and (R(4)='1')) and
                (not ((K(1)='1') and (R(1)='1') and (R(4)='0'))))))))
              then nextstate <= 1;
              elsif (K = "000" and R = "0000") then nextstate <= 2;
              else nextstate <= 0;
              end if;
    when 2 to 30 => nextstate <= state + 1;
    when 31 => nextstate <= 0;
  end case;
end process;
```

```
debug_output: -- display the state
q <= conv_std_logic_vector(state,5);
```

```
output_decoder: -- output decoder part
process(state)
begin
  case state is
    when 0 to 1 => UNLOCK <= '0';
    when 2 to 31 => UNLOCK <= '1';
  end case;
end process;
```

```
state_register: -- the state register part (the flipflops)
process(clk)
begin
  if rising_edge(clk) then
    state <= nextstate;
  end if;
end process;
end behavior;
```

Now it's hard to see if this is correct or not?

Does both expressions mean the same?

```
( K = "100" and R ="0001" )
```

Is this really the same thing?

```
((R(2)='0') and (R(3)='0') and (K(2)='0') and (K(3)='1')) and  
( not (( not ((K(1)='0') and (R(1)='0') and (R(4)='1')))) and  
( not ((K(1)='1') and (R(1)='1') and (R(4)='0'))))))
```

*Someone "promises" that the code is correct - but
how can you know that this is absolutely true?*

tb_lockmall.vhd

We need to write a VHDL-testbench

A test bench program can test all the possible key combinations and report if there is a problem ...

It can automatically loop through all possible key-presses and report on whether the lock trying to open or not.

There are $2^7 = 128$ possible key combinations and we'd be totally exhausted if we tried to test them all by hand.

entity – a testbench has no ports

```
entity tb_codelock is  
  -- entity tb_codelock has no ports  
  -- because it's for simulation only  
end tb_codelock;
```

Some internal signals are needed

```
signal      clk : std_logic := '0';
signal      K_test : std_logic_vector(1 to 3);
signal      R_test : std_logic_vector(1 to 4);
signal      prev_K_test : std_logic_vector(1 to 3);
signal      prev_R_test : std_logic_vector(1 to 4);
signal      q : std_logic_vector(4 downto 0);
signal      unlock : std_logic;
```

Our codeclock is used as a component

```
-- we use our codeclock as a component
component codeclock
  port( clk : in std_logic;
        K : in std_logic_vector(1 to 3);
        R : in std_logic_vector(1 to 4);
        q : out std_logic_vector(4 downto 0);
        UNLOCK : out std_logic );
end component;
```

Generate a simulation clock

```
-- generate a simulation clock
clk <= not clk after 10 ns;
```

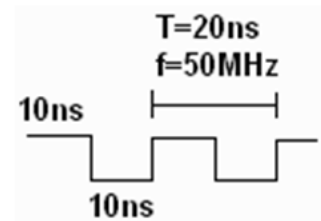

Instantiation and signal mapping

```
-- instantiation of the device under test,
-- mapping of signals
inst_codeclock:
  codeclock
  port map (
    clk => clk,
    K => K_test,
    R => R_test,
    q => q,
    UNLOCK => unlock );
```

Two nested loops creates keystrokes

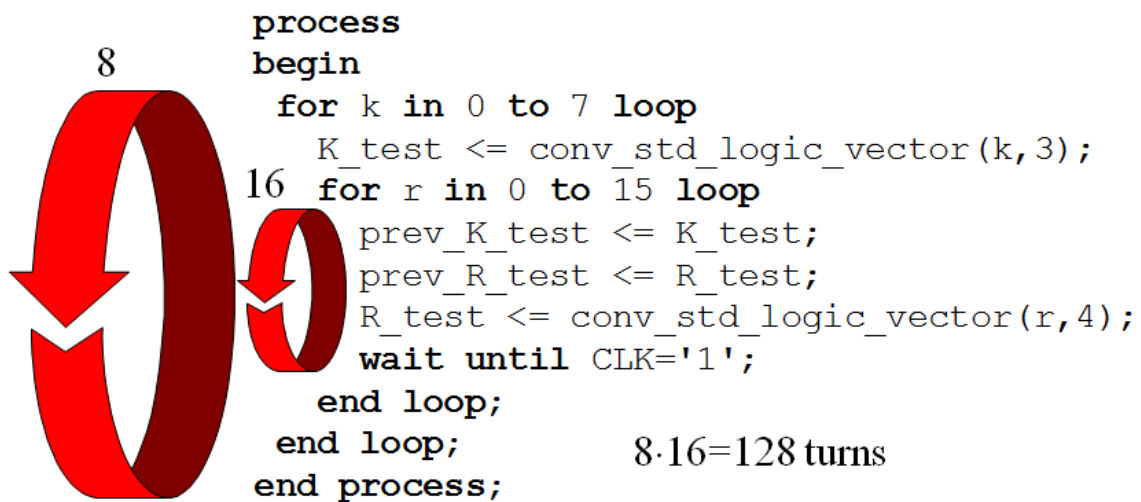

report, severity **note**, severity **error**

Tests if state $q = "00001"$ will be reached by any combination.

check:

```

process (q)
begin if ((q = "00001") and
  (prev_K_test = conv_std_logic_vector(1,3)) and
  (prev_R_test = conv_std_logic_vector(1,4)))
then assert false report
  "Lock tries to open for the right sequence!"
  severity note;
else if ((q = "00001"))
then
  assert false report
  "Lock tries to open with the wrong sequence!"
  severity error;
else report "Lock closed!" severity note;
  end if;
end if;
end process check;

```

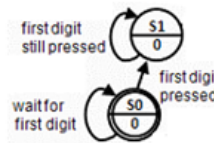

Simulate and find the error!

What else besides pressing the "1" key could open the lock?

?

