

VT2008 SK2410 IO2659 Examination Tasks

Task 1.

(a) Explain homogeneous and inhomogeneous spectral line broadening

Group the following laser gain media in two columns according to whether the gain spectral line is homogeneously or inhomogeneously broadened:

Nd:YAG, Nd:glass fiber, Er:glass fiber, Ti:Sapphire, He-Ne, Ar⁺ ion plasma, CO₂, Yb:YAG, GaAs, Alexandrite, Ruby. (1 point)

(b) Which physical mechanisms are primarily responsible for the gain linewidth broadening in Nd:YAG, Ti:Sapphire, He-Cd, Nd:glass. (1 point).

(c) Derive the equation relating spontaneous emission lifetime τ_{sp} to the peak transition cross-section $\sigma(0)$ and observed FWHM linewidth $\Delta\nu_0$ for a dipole allowed-transition in an isolated atom. (2 points).

Task 2

(a) Explain gain saturation in homogeneously and inhomogeneously broadened laser media. (1 point).

(b) You have a choice of two laser gain materials for making high energy Q-switched laser. One gain medium employs partly dipole-forbidden transitions, the other employs dipole-allowed transitions. Both media operate at the same wavelength. Which one would you choose for the laser and why? (1 point).

(c) Calculate pulse energy at the output of 6 mm -long Nd:YAG amplifier rod with diameter of 3 mm. The amplifier rod is pumped to initial population inversion of $2.7 \times 10^{19} \text{ cm}^{-3}$, input 10 ns pulse energy is 1 mJ. Assume that the pulse length is longer than the lifetime of the lower laser level. The input wavelength is 1064 nm. Assume that the beam is circular and totally fills the amplifier diameter. The stimulated emission cross-section for this transition is $2.8 \times 10^{-19} \text{ cm}^2$.

Plank constant $6.626 \times 10^{-34} \text{ Js}$

Speed of light $3 \times 10^{10} \text{ cm/s}$

(2 points)

Task 3.

(a) You have choice of materials: SiO₂ glass, amorphous Si, CH₄ gas, and a crystal KTiOPO₄ with ortho-rhombic structure. Which materials would you not use for the second harmonic generation and why? (1 point).

(b) Can optical parametric oscillator operate in Q-switched mode? Motivate your answer. (1 point).

(c) You have a Nd:YAG laser operating simultaneously at two wavelengths corresponding to two transitions at wavelengths of 1064 nm and 1319 nm. Your task is to make a laser display emitting three primary colours in blue (around 440 nm), green (around 532 nm) and red (around 660 nm). Propose a route to get to these wavelength ranges starting from two available wavelengths in the near infrared. (2 points).

Task 4.

- (a) Describe the four most characteristic properties of laser beams, and state their relations with respect to each other. (1 point)
- (b) Explain the phenomenon: laser speckle. What will happen if the laser source is replaced by a thermal light source? (1 point)
- (c) The speckle pattern observed when an expanded He-Ne laser beam at $\lambda=632\text{nm}$ illuminates a diffusing area of diameter $D=0.5\text{ cm}$ shows a grain size of d_g about 0.6 mm . What is the estimated distance L of the scattered surface from the observation plane? (1 point)
- (d) Assume now the speckle pattern is seen by a human observer that looks at the scattering surface. What is the apparent grain size on the scattering surface observed by the human eye? Assume the pupil diameter $D'=1.8\text{ mm}$. (1 point)

Task 5.

- (a) Describe the phenomena of relaxation oscillation. (1 point)
- (b) A Nd:YAG laser operates twice above the threshold. Assume a cavity length $L=20\text{ cm}$, a Nd:YAG rod of length $l=0.8\text{ cm}$, a refractive index of YAG $n=1.82$, an upper state laser life time $\tau=230\text{ }\mu\text{s}$, and overall round-trip logarithmic loss of $\gamma=2\%$. Laser wavelength $\lambda=1064\text{ nm}$. Calculate the relaxation oscillation frequency. (1 point)
- (c) The same laser is actively mode-locked by an acousto-optic modulator. Calculate the expected pulse length for the case of a homogeneously-broadened gain-line of width $\Delta\nu_0=195\text{ GHz}$, and also for the case of inhomogeneously broadened gain-line. (1 point)
- (d) The same laser but is now passively mode-locked by a fast saturable absorber, emits a pulse train at a repetition rate $\nu_m=100\text{ MHz}$, each pulse having a duration $\Delta\tau_p=10\text{ ps}$ (FWHM of pulse intensity). The average output power is $P_{av}=500\text{ mW}$. Calculate pulse energy and peak pulse power of the emitted pulse train. Hint: In a passively mode-locked laser with homogeneous gain line and fast saturable absorber, the steady-state pulse amplitude is described by a hyperbolic secant function, so that the output pulse power can be written as $P(t)=P_p\text{sech}^2(t/\tau_p)$, where P_p is the pulse peak power and $\tau_p=\Delta\tau_p/1.76$. $\int_{-\infty}^{+\infty} \text{sech}^2 x dx = 2$. (1 point)

Task 6.

- (a) A Nd:YAG rod with a diameter of 4 mm, a length of 6.5 cm and 1 atom.% Nd doping is transversely pumped at 808 nm wavelength in the pump configuration shown below. Assume that 90% of the optical power emitted from the pumping fibers is uniformly absorbed in the rod and that the mode spot size is 0.7 times the rod radius (optical spot). To obtain high power from the laser, and output mirror of 15% transmission is used. Including other internal losses, a loss per single pass of $\gamma=10\%$ is estimated. If the effective stimulated emission cross section is taken as $\sigma_e=2.8 \times 10^{-19} \text{ cm}^2$ and the upper laser level lifetime is $\tau=230 \text{ } \mu\text{s}$, calculate the optical power required from the fibers to reach laser threshold.
(2 points)

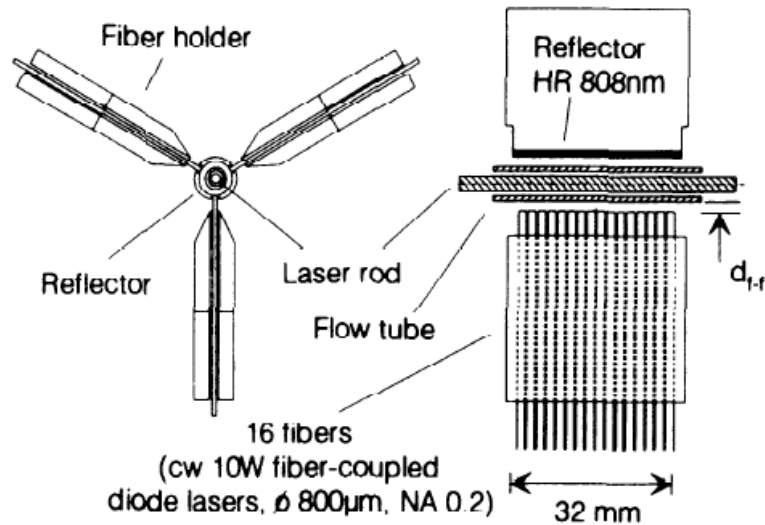

- (b) The rod is now pumped longitudinally in the configuration shown below. Assume that the transmission at pump wavelength of the HR mirror directly coated on the rod is $T_p=95\%$, and the absorption coefficient of the active medium at pump wavelength is $\alpha=4 \text{ cm}^{-1}$. Other parameters (single pass loss, mode spot size, etc) are the same as in (a). Calculate the optical pump power required at threshold when optimum pumping conditions are realized. Compare the results with those obtained in (a).
(2 points)

